

the better way to heat

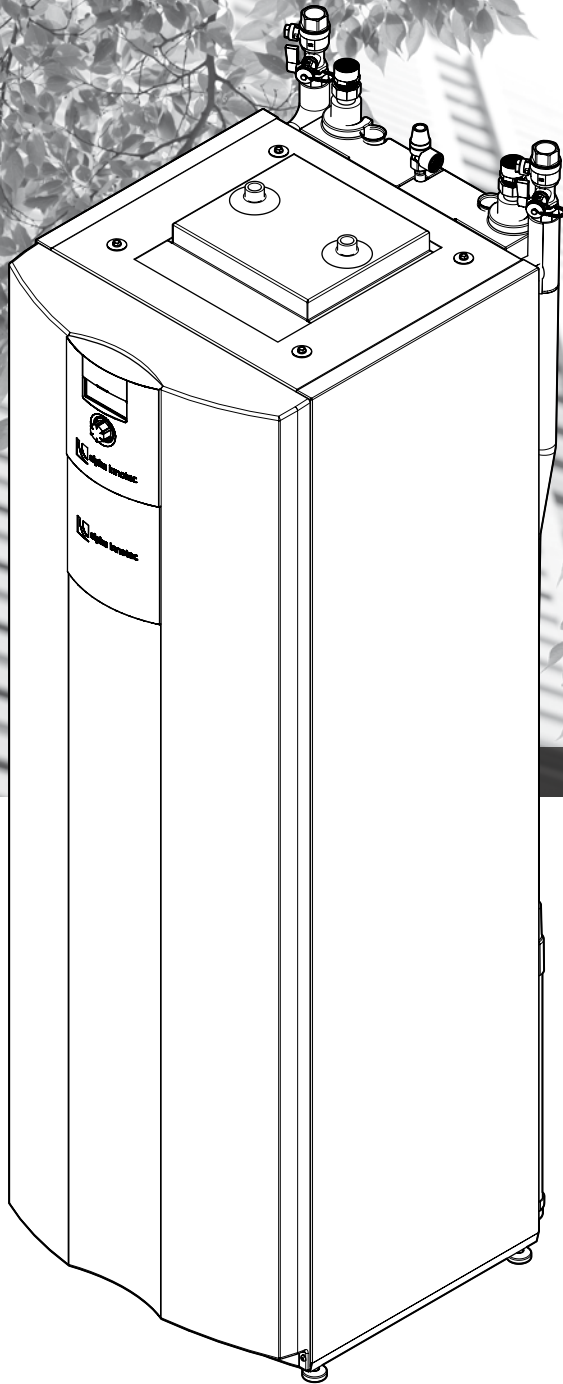
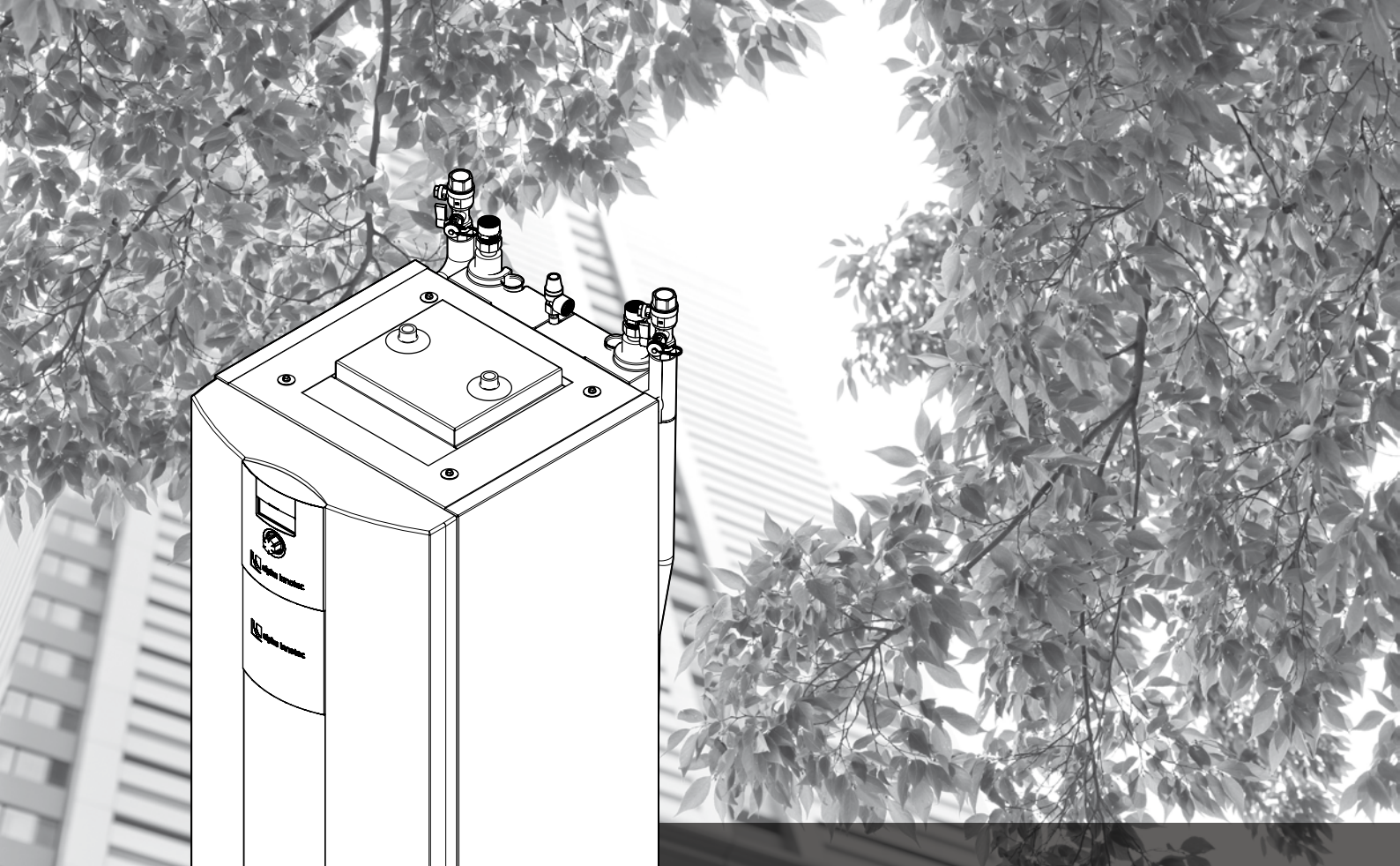

Brine/water heat pumps

Operating Manual

WZS V series





Contents

1	About this operating manual.....	3
1.1	Validity.....	3
1.2	Reference documents.....	3
1.3	Symbols and identification markings.....	3
1.4	Contact.....	4
2	Safety.....	4
2.1	Intended use.....	4
2.2	Personnel qualifications.....	4
2.3	Personal protective equipment.....	4
2.4	Residual risks.....	4
2.5	Disposal.....	5
2.6	Avoid damage to property.....	5
3	Description.....	6
3.1	Layout.....	6
3.2	Accessories.....	8
3.3	Function.....	8
4	Operation and care.....	9
4.1	Energy and environmentally aware operation.....	9
4.2	Maintenance.....	9
5	Delivery, storage, transport and installation.....	9
5.1	Scope of supply.....	9
5.2	Storage.....	9
5.3	Unpacking and transport.....	10
5.4	Installation.....	11
6	Installation and connection.....	11
6.1	Dismantle the module box.....	11
6.2	Installing the module box.....	15
6.3	Install the hydraulic connections.....	15
6.4	Connect the electrical cables.....	16
6.5	Installing the control unit.....	17
7	Flushing, filling and venting.....	18
7.1	Remove the front panel of the module box.....	18
7.2	Heating water quality.....	18
7.3	Fill, flush and vent heat source.....	19
7.4	Vent the circulation pump of the heat source.....	19
7.5	Flush and fill the heating and domestic hot water charge circuit.....	20
7.6	Flush, fill and vent the domestic hot water tank.....	20
8	Insulate hydraulic connections.....	21
9	Set the overflow valve.....	21
10	Commissioning.....	22
11	Maintenance.....	22
11.1	Basic principles.....	22
11.2	Maintenance as required.....	22
11.3	Yearly maintenance.....	22
11.4	Clean and flush the evaporator and condenser.....	23
12	Faults.....	23
12.1	Unlock the safety temperature limiter.....	23
13	Dismantling and Disposal.....	23
13.1	Dismantling.....	23
13.2	Disposal and Recycling.....	23
	Performance curves.....	26
	Dimensioned drawings.....	28
	Installation plans.....	30
	Hydraulic integration, unit variant H (heating) ..	33
	Terminal diagram.....	38
	Terminal diagram.....	39
	Circuit diagram 1/3.....	40
	EC Declaration of Conformity.....	46



1 About this operating manual

This operating manual is part of the unit.

- ▶ Before working on or with the unit read the operating manual carefully and follow it for all activities at all times, especially the warnings and safety instructions.
- ▶ Keep the operating manual to hand at the unit and hand over to the new owner if the unit changes hands.
- ▶ If you have any questions or anything is unclear, ask the local partner of the manufacturer or the factory's customer service.
- ▶ Note and follow all reference documents.

1.1 Validity

This operating manual refers solely to the unit identified by the nameplate and unit sticker (→ "Rating plate" on page 6 and "Unit sticker" on page 3).

1.2 Reference documents

The following documents contain additional information to this operating manual:

- Planning & design manual, hydraulic integration
- Operating manual of the heating and heat pump controller
- Brief description of the heat pump controller
- Operating manual of the expansion board
- Logbook, if included with this unit by the manufacturer

Unit sticker

The unit sticker contains important information for contact with the manufacturer or the local partner of the manufacturer.

- ▶ Stick on the unit sticker (barcode with serial and product number) here.



1.3 Symbols and identification markings

Identification of warnings

Symbol	Meaning
	Safety-relevant information. Warning of physical injuries.
DANGER	Indicates imminent danger resulting in severe injuries or death.
WARNING	Indicates a potentially dangerous situation, which can result in severe injuries or death.
CAUTION	Indicates a potentially dangerous situation, which can result in moderate or minor injuries.
ATTENTION	Indicates a potentially dangerous situation, which can result in property damage.

Symbols in the document

Symbol	Meaning
	Information for the professional
	Information for the owner/operator
✓	Requirement for an action
▶	Single step action prompt
1., 2., 3. ...	Numbered step within a multi-step action prompt. Keep to the given order.
	Additional information, e.g. note on easier work, information on standards
→	Reference to further information elsewhere in the operating manual or in another document



1.4 Contact

Addresses for purchasing accessories, for service cases or for answers to questions about the unit and this operating manual can be found on the internet at any time and is kept up to date:

- Germany: www.alpha-innotec.de
- EU: www.alpha-innotec.eu

2 Safety

Only use the unit if it is in proper technical condition and only use it as intended, safely and aware of the hazards, and follow this operating manual.

2.1 Intended use

The unit is solely intended for the following functions:

- Heating
- Domestic water heating
- Cooling (optional, with accessories or unit type ...K3M)
- ▶ Proper use includes complying with the operating conditions (→ “Technical data/Scope of supply” on page 24) and the operating manual and noting and following the reference documents.
- ▶ When using the local regulations note: laws, standards, guidelines, directives.

All other uses of the unit are not as intended.

2.2 Personnel qualifications

All instructional information in this operating manual is solely directed at qualified, skilled personnel.

Only qualified, skilled personnel is able to carry out the work on the unit safely and correctly. Interference by unqualified personnel can cause life-threatening injuries and damage to property.

- ▶ Ensure that the personnel is familiar with the local regulations, especially those on safe and hazard-aware working.
- ▶ Only allow qualified personnel with “electrical” training to carry out work on the electrics and electronics.

- ▶ Only allow skilled personnel to do any other work on the system, e.g.
 - Heating installer
 - Plumbing installer
 - Refrigeration system installer (maintenance work)

During the warranty and guarantee period, service work and repairs may only be carried out by personnel authorised by the manufacturer.

2.3 Personal protective equipment

There is a risk of cutting your hands on sharp edges of the unit.

- ▶ Wear cut-resistant protective gloves during transport.

2.4 Residual risks

Electric shock

Components in the unit are live with life-threatening voltage. Before opening the unit panelling:

- ▶ Disconnect unit from power supply.
- ▶ Protect unit against being switched back on again.

Injury due to flammable liquids and potentially explosive atmospheres

Constituents of antifreeze mixtures, e.g. ethanol, methanol, are highly flammable and form an explosive atmosphere:

- ▶ mix antifreeze in well-ventilated rooms.
- ▶ Note the hazardous substance markings and comply with the relevant safety regulations.



Injuries and environmental damage due to refrigerant

The unit contains harmful and environmentally dangerous refrigerant. If refrigerant leaks from the unit:

1. Switch off unit.
2. Thoroughly ventilate installation room.
3. Notify authorised customer service.

2.5 Disposal

Batteries

Improper disposal of the buffer battery damages the environment.

- ▶ Dispose of the buffer battery in an environmentally compatible way according to the local regulations.

Media harmful to the environment

Improper disposal of environmentally harmful media (antifreeze, refrigerant) damages the environment:

- ▶ Collect media safely.
- ▶ Dispose of the media in an environmentally compatible way according to the local regulations.

2.6 Avoid damage to property

Improper action

Requirements for minimum scale and corrosion damage in hot water heating systems:

- Proper planning, design and start-up
- Closed system with regard to corrosion
- Integration of adequately dimensioned pressure generation
- Use of deionised heating water (VE water)
- Regular servicing and maintenance

If a system is not planned, designed, started up and operated according to the named requirements, there is a risk that the following damage and faults will occur:

- Malfunctions and the failure of components, e.g. pumps, valves
- Internal and external leaks, e.g. from heat exchangers
- Cross-section reduction and blockages in components, e.g. heat exchanger, pipes, pumps
- Material fatigue

- Gas bubbles and gas cushion formation (cavitation)
- Negative effect on heat transfer, e.g. formation of coatings, deposits, and associated noises, e.g. boiling noises, flow noises
- ▶ Note and follow the information in this operating manual for all work on and with the unit.

Unsuitable quality of the fill and make-up water in the heating circuit

The efficiency of the system and the life of the heat generator and the heating components depend decisively on the quality of the heating water.

If the system is filled with untreated domestic water, calcium precipitates as scale. Limescale deposits form on the heat transfer surfaces of the heating. The efficiency drops and energy costs rise. In extreme cases the heat exchangers are damaged.

- ▶ Fill system with deionised heating water (VE water) only.

Unsuitable quality of the water in the domestic hot water tank

- ▶ Ensure that the electrical conductivity of the domestic water is at least 100 $\mu\text{S}/\text{cm}$.

Unsuitable quality of the water-antifreeze mixture in the heat source

- ▶ For operation of the heat source with water-antifreeze mixture, ensure that the water fulfils the quality specifications of the heating water side.



3 Description

3.1 Layout



NOTE

This section essentially names the components relevant for fulfilling the tasks described in this operating manual.

Heat station

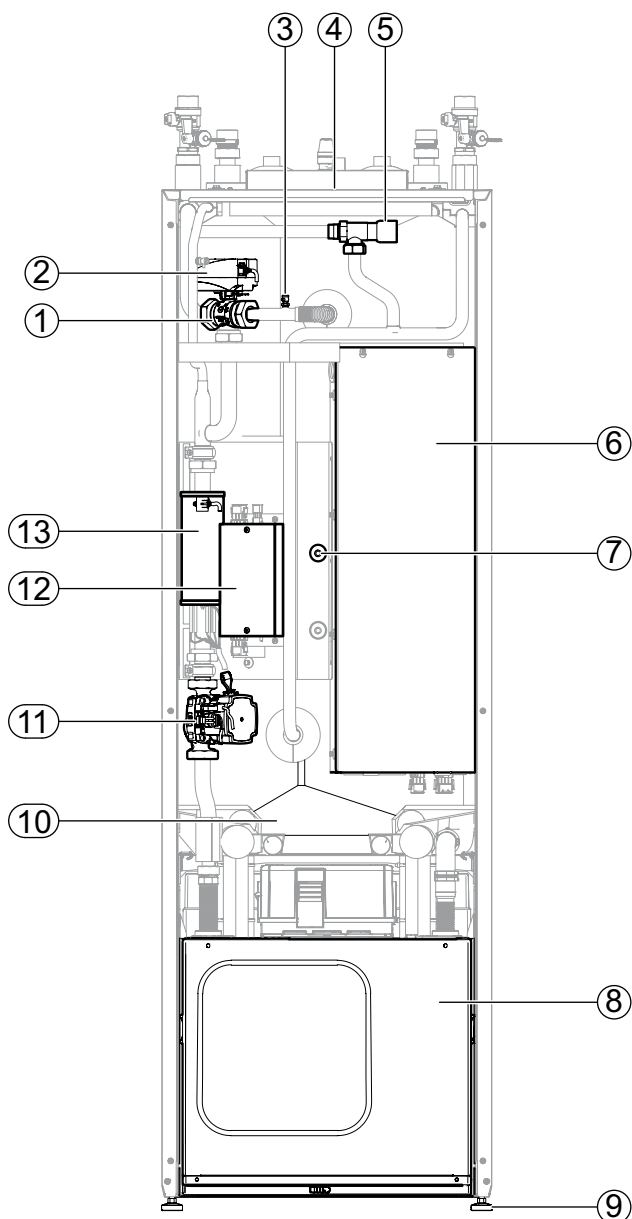

- 1 3-way changeover valve, heating circuit/domestic hot water
- 2 Valve motor
- 3 Venter
- 4 Position of rating plate
- 5 Overflow valve
- 6 Electrical switch cabinet
- 7 Domestic hot water tank sensor
- 8 Module box
- 9 Height-adjustable foot (4x)
- 10 Domestic hot water tank
- 11 Heating circuit/hot water circulation pump
- 12 Manual output control heating element (MLRH), accessories
- 13 Heating element

Rating plate

One rating plate is attached at the top of the heating station, a second one on the left on the module box. The rating plate contains the following information at the top:

- Unit type, product number
- Serial number, unit index

The rating plate also contains an overview of the most important technical data.



Module box, variant without cooling

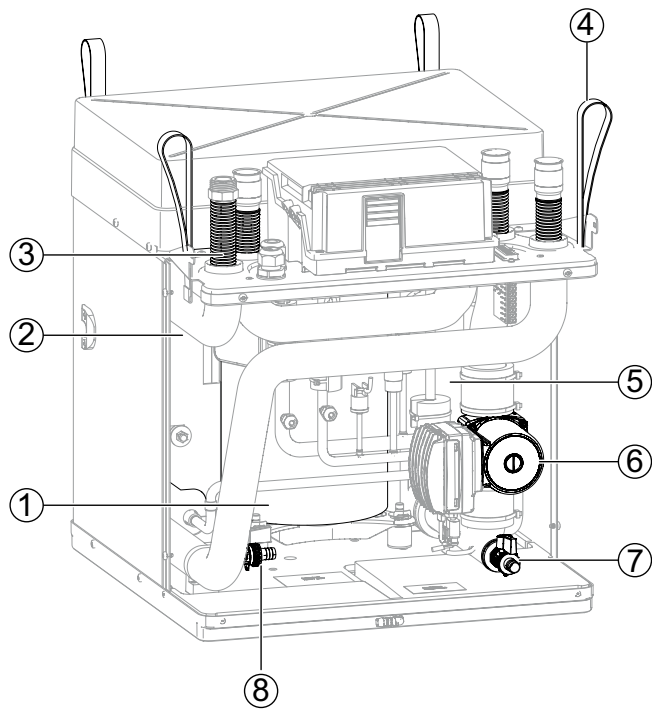

- 1 Compressor
- 2 Condenser
- 3 Vibration isolator (4x)
- 4 Lifting lug (4x)
- 5 Evaporator
- 6 Heat source circulation pump
- 7 Heat source filling and drain tap
- 8 Heating filling and drain tap

Module box, variant with cooling

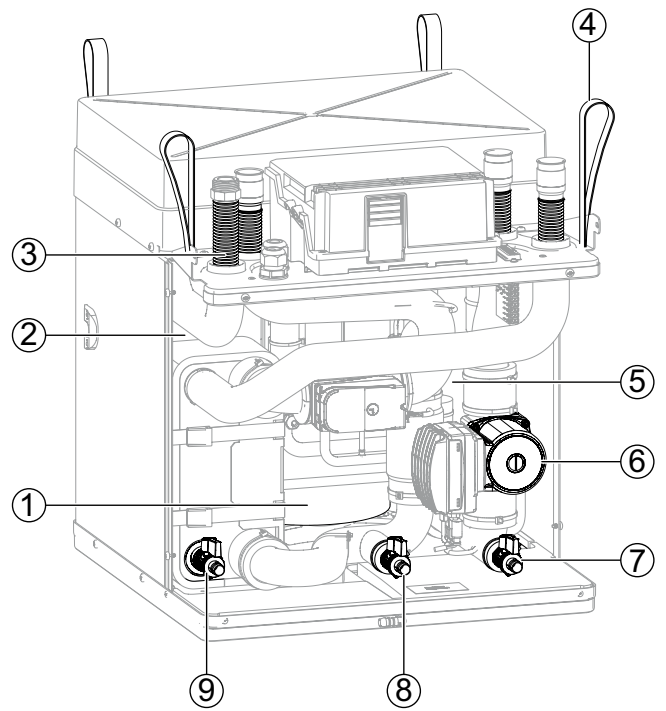

- 1 Compressor
- 2 Condenser
- 3 Vibration isolator (4x)
- 4 Lifting lug (4x)
- 5 Evaporator
- 6 Heat source circulation pump
- 7 Heat source filling and drain tap
- 8 Heat source filling and drain tap
- 9 Heating filling and drain tap



Control unit

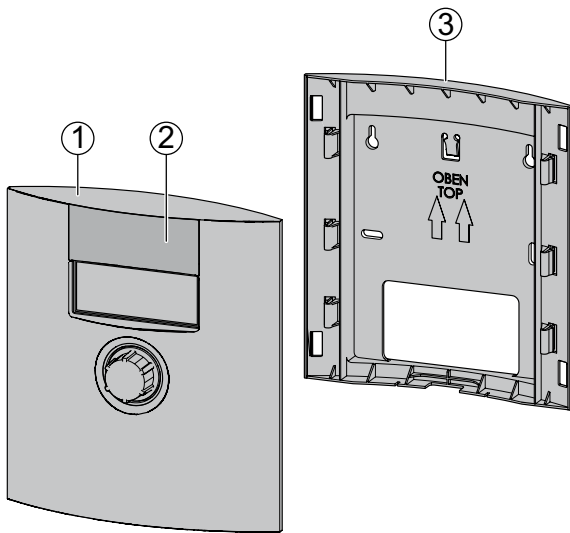

- 1 Control unit
- 2 Push up flap upstream of USB connection (for qualified personnel for software updates and for data logging)
- 3 Wall-mounted bracket (only necessary for wall-mounted installation)

Underside of control unit

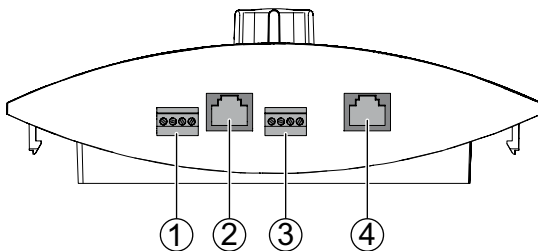

- 1 RBE (RS 485)
- 2 Network cable connection
- 3 LIN bus cable connection to the heat pump
- 4 not used

3.2 Accessories

The following accessories are available for the unit through the manufacturer's local partner:

- Additional cover for the front cover panel, if the control unit is mounted on the wall
- Room thermostat for switching the cooling function (if available)
- Dew point monitor for protecting a system with cooling function at low flow temperatures
- Expansion board for automatic changeover between heating and cooling mode
- Manual output control heating element (MLRH) for limiting the output of the electric heating element
- "Cooling package" for retrofitting type H units with a cooling function

3.3 Function

Liquid refrigerant is evaporated (evaporator), the energy for this process is environmental heat and comes from the "ground" heat source (collector, borehole heat exchanger or groundwater via intermediate exchanger). The gaseous refrigerant is compressed (compressor), this causes the pressure to rise and therefore the temperature too. The gaseous refrigerant with high temperature is liquefied (condenser).

Here the high temperature is discharged to the heating water and is used in the heating circuit. The liquid refrigerant with high pressure and high temperature is expanded (expansion valve). The pressure and temperature drop and the process begins again.

Due to the integrated changeover valve and the integrated energy efficiency circulation pump the heated heating water can be used for charging the domestic hot water or for heating the building. The temperatures required and use are controlled by the heat pump controller. Reheating, drying out screed or increasing the domestic hot water temperature can be carried out using the integrated electric heating element, which is activated by the heat pump controller as and when necessary.

An integrated overflow valve ensures that the heat pump does not switch to high-pressure fault if all heating circuits are closed. The integrated vibration isolators for the heating circuit and heat source prevent structure-borne sound and vibrations from being transferred onto the fixed pipes and therefore into the building.



Cooling

Cooling is integrated in type K units. Type H units can be retrofitted with the "Cooling package" accessories. The following options are possible for units with cooling function (→ operating manual of the heating and heat pump controller):

- Passive cooling (without compressor)
- Control of the cooling function via the heating and heat pump controller
- Switching between heating and cooling mode; automatically with expansion board (accessories)

Network connection on the control unit

The control unit can be connected to a computer or network via a network cable. The heating and heat pump controller can then be controlled from the computer or from the network.

4 Operation and care



NOTE

The unit is operated via the control unit of the heating and heat pump controller (→ operating manual of the heating and heat pump controller).

4.1 Energy and environmentally aware operation

The generally accepted requirements for energy-aware and environmentally-aware operation of a heating system also apply to use of a brine/water heat pump. The most important measures include:

- No unnecessarily high flow temperature
- No unnecessarily high domestic hot water temperature (note and follow local regulations)
- Do not open windows with gap /tilt open (continuous ventilation), but instead open wide for a short time (purge ventilation).

4.2 Maintenance

Wipe down the outside of the unit only using a damp cloth or cloth with mild cleaning product (washing-up liquid, neutral cleaning product). Do not use any harsh, abrasive, acid or chlorine-based cleaning products.

5 Delivery, storage, transport and installation

5.1 Scope of supply



NOTE

On delivery the accessories are enclosed in two packages on the heating station.

- ▶ Check delivery immediately after receipt for outwardly visible damage and completeness.
- ▶ Notify supplier of any defects immediately.

The separate pack included contains:

- Sticker with the unit number for attaching to page 3 of this manual
- Control unit consisting of wall bracket, cover, control with rear bracket
- 6-mm anchors with screws (2x each) for wall-mounting the control unit
- Safety valve, outdoor sensor
- Compression fittings
- Replacement material after dismantling the module box: Insulation hoses (2x), cable ties (4x), O-rings (6x)

5.2 Storage

- ▶ Where possible do not unpack the unit until directly before installation.
- ▶ Store unit protected against:
 - Moisture/damp
 - Frost
 - Dust and dirt



5.3 Unpacking and transport

Notes on safe transport

The heating station and the module box are heavy (→ “Technical data/Scope of supply” on page 24). There is a risk of injuries or damage to property if the heating station falls or overturns or if the module box falls.

- ▶ The heating station and module box must be transported and installed by several persons.
- ▶ Secure the heating station during transport. Carry the module box by the carrying lugs.

There is a risk of cutting your hands on sharp edges of the unit.

- ▶ Wear cut resistant protective gloves.

The hydraulic connections are not designed for mechanical loads.

- ▶ Do not lift or transport the unit by the hydraulic connections.

If the module box is tilted by more than 45°, compressor oil runs into the cooling circuit.

- ▶ Do not tilt the unit with installed module box by more than 45°.

Transport the unit preferably with a pallet truck, alternatively with a handcart.

Transport with a pallet truck

- ▶ Transport the unit to the place of installation packaged and secured on a wooden pallet.

Unpacking



NOTE

If the unit is not transported by a pallet truck: Do not lift off the pallet until after unpacking and dismantling the housing panels.

1. Remove plastic films. Ensure that you do not damage the unit.
2. Dispose of the mounting bracket, transport and packaging material in an environmentally friendly way according to local regulations.
3. Remove the film from the plastic element of the front panel in the place of installation.

Dismantle housing panels for transport with handcart or carrying the unit

- ✓ Unit is unpacked (→ “Unpacking” on page 10).
- 1. To avoid damage to the housing panels:
 - Undo 2 screws at the bottom of the front panel.
 - Lift up the front panel and put down in safe place.
 - Undo 3 screws in each side panel.
 - Lift up side panels and put down in safe place.

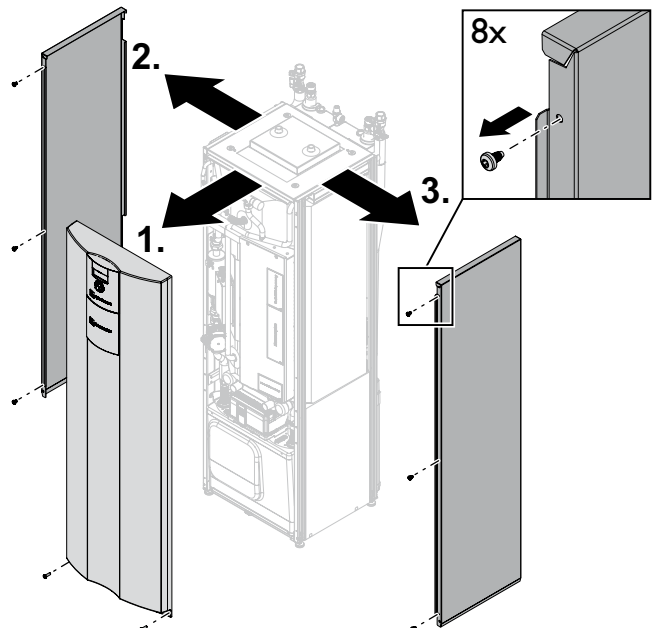

Transport with a handcart



NOTE

- If transporting with a handcart the module box must be pushed in.
 - This figure with the handcart shows transporting the unit on its left-hand side; it can also be transported on its right-hand side.
- ✓ Housing panels are dismantled.



1. To avoid damage: On a handcart, load the unit on its side only.

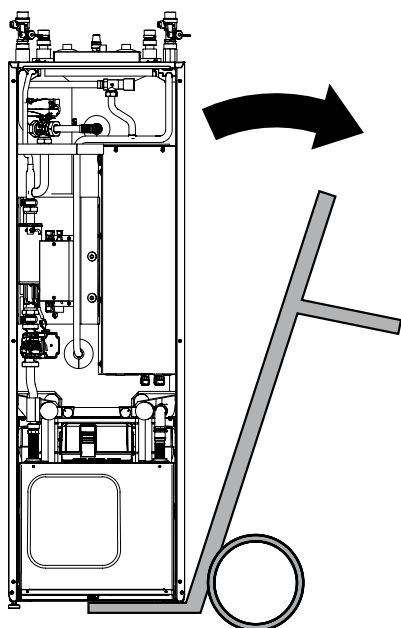

2. Transport unit on the handcart.

Carrying the unit

- ✓ Housing panels are dismantled.

 1. Dismantle module box and carry it by the support lugs to the place of installation.
 2. Carry the unit horizontally wherever possible.

5.4 Installation

Installation room and space requirements



NOTE

Note and follow the local regulations and standards regarding the installation room and space requirements. The table shows the regulations to EN 378-1 relevant in Germany.

Refrigerant	Limit value [kg/m ³]
R 134a	0.25
R 404A	0.48
R 407C	0.31
R 410A	0.44

(→ “Technical data/Scope of supply” on page 24).

$$\text{Minimum room volume} = \frac{\text{Refrigerant capacity [kg]}}{\text{Limit value [kg/m}^3\text{]}}$$



NOTE

If several heat pumps of the same type are installed only one heat pump need to be taken into account. If several heat pumps of different types are installed, only the heat pump with the largest refrigerant volume needs to be taken into account.

- ✓ Minimum volume corresponds to the requirements for the refrigerant used.
- ✓ Installation inside the building only.
- ✓ Installation room is dry and frost-free.
- ✓ Clearance dimensions are met (→ “Installation plans” on page 30).
- ✓ The surface/floor is suitable for installation of the unit:
 - level and horizontal
 - load-bearing capacity for the unit's weight

Aligning the unit

- ▶ Align the unit horizontally and stably in the installation site using the height-adjustable feet and a spanner size SW 13. Adjustment range: 25 to 50 mm.

6 Installation and connection

6.1 Dismantle the module box

ATTENTION

If the module box is tilted by more than 45°, compressor oil runs into the cooling circuit.

- ▶ Do not tilt the module box by more than 45°.



NOTE

- If necessary the module box can be dismantled for easier transport of the unit or for service reasons.
- Steps 1 to 5 are only required if the module box is connected and filled.
- ✓ **Unit** is safely disconnected from the power supply and protected against being switched back on again.



1. Remove the front panel of the module box (→ “7.1 Remove the front panel of the module box” on page 18).
2. Close shut-off valves to the heating circuit.

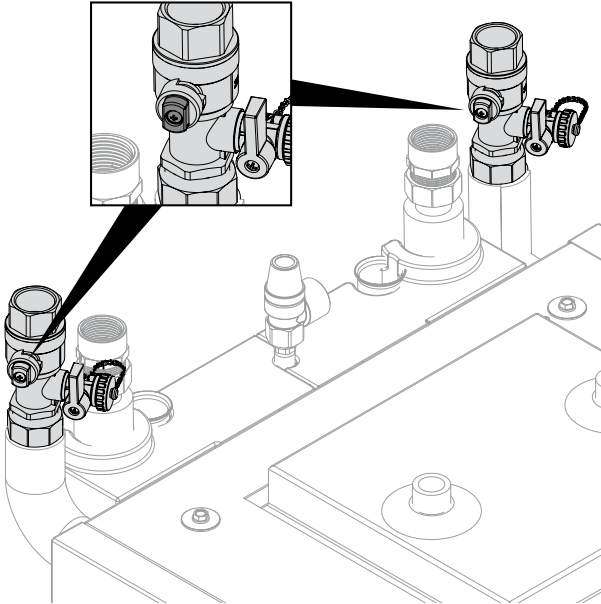

3. Drain the unit via the filling and drain tap of the heating.

► **Unit without cooling:**

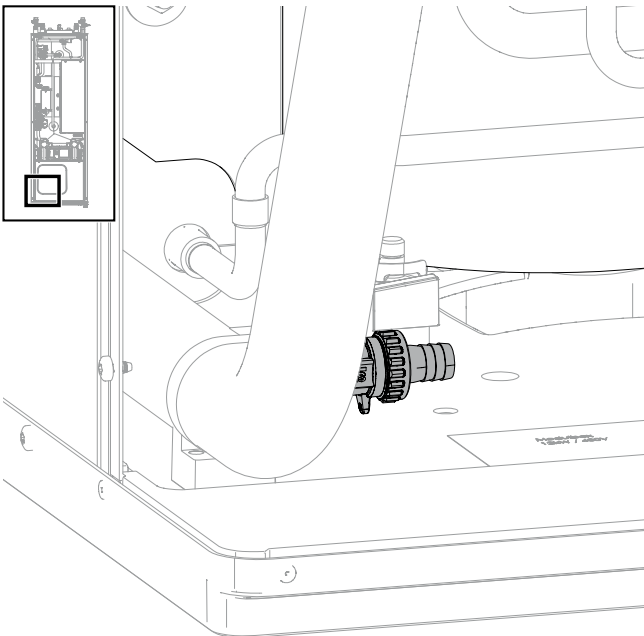

► **Unit with cooling:**

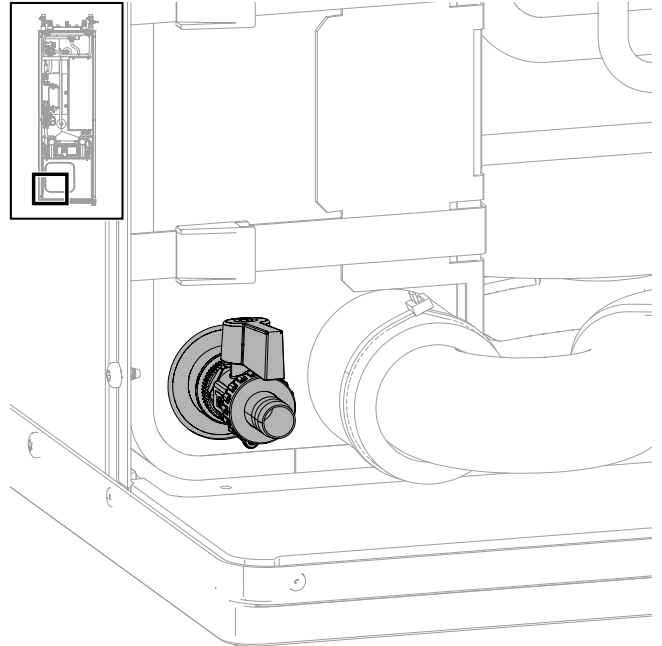

4. Use a spanner to close the shut-off valves of the heat source (behind the covers).

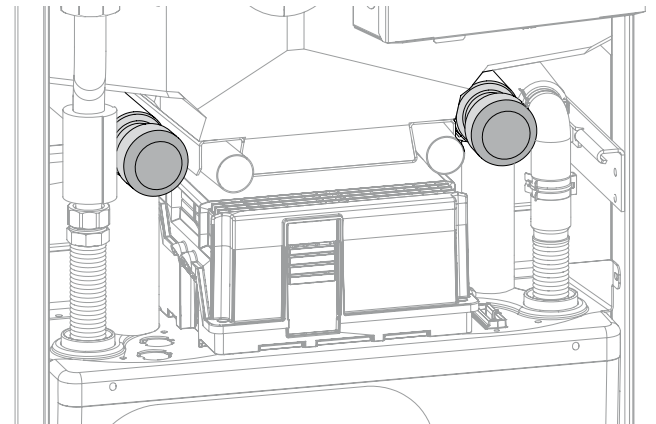

5. Drain the unit via the filling and drain tap of the heat source.

► **Unit without cooling:**

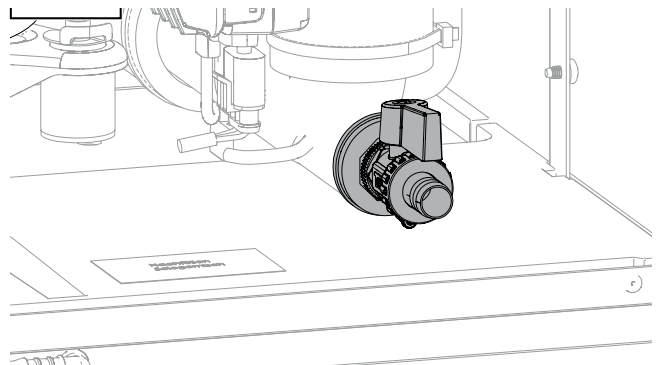



► **Unit with cooling:**

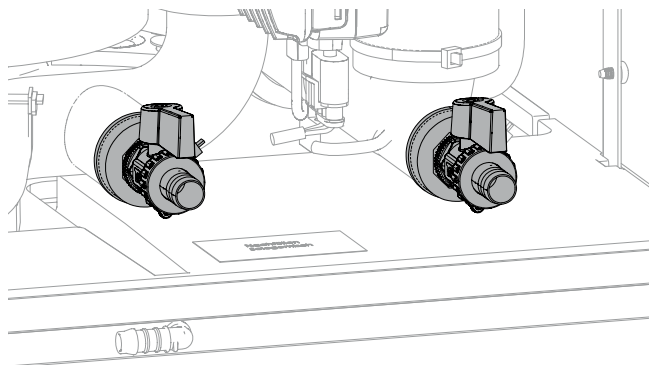

6. Disconnect the electrical connections.

- Disconnect 2 white connectors (1) at the bottom of the electrical control cabinet. To do this, release the latching lugs by pressing on the sides of the connectors.
- Pull out the black rectangular connector (2) at the top of the module box.

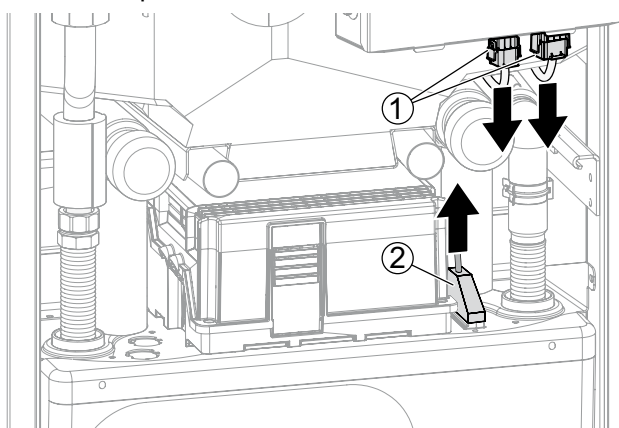

7. Remove the insulation on the hydraulic connections.

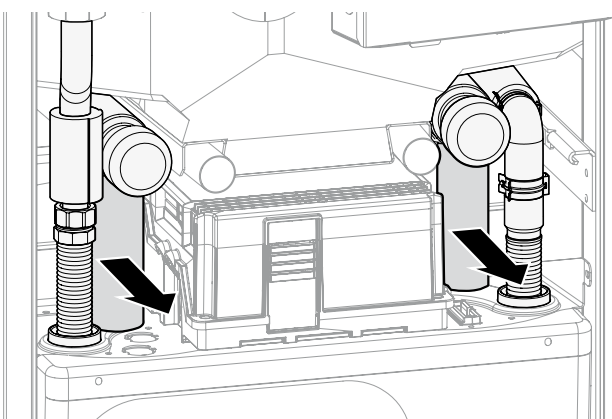

8. Remove 3 clips on the hydraulic connections.

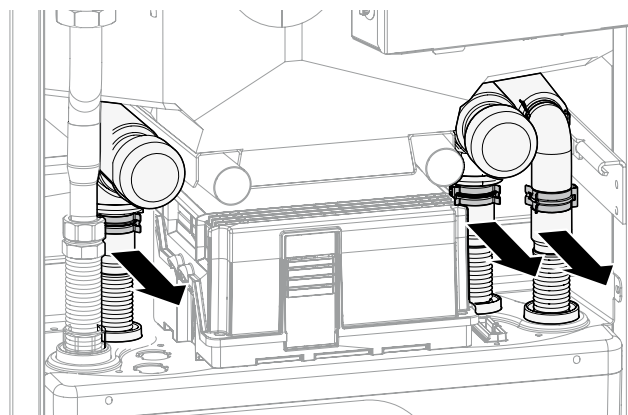

9. Use spanner size SW 37 to unscrew the heating flow.

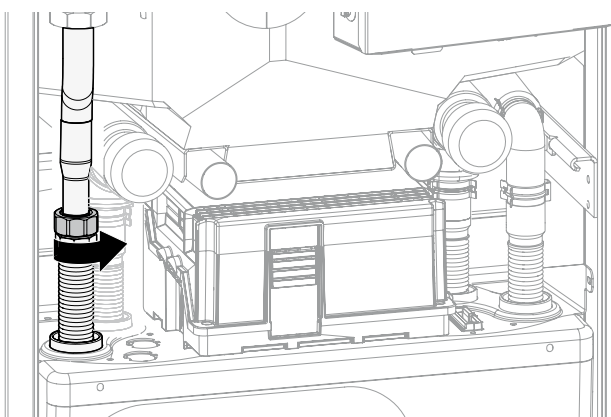

10. Disconnect the hydraulic connections; to do this, push the pipes downwards as far as necessary.

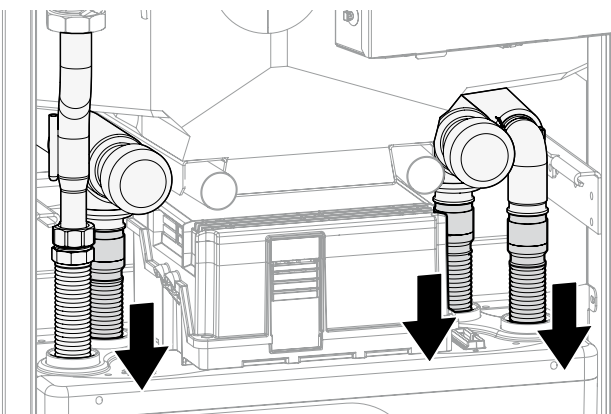



11. Remove the 2 side retaining screws.

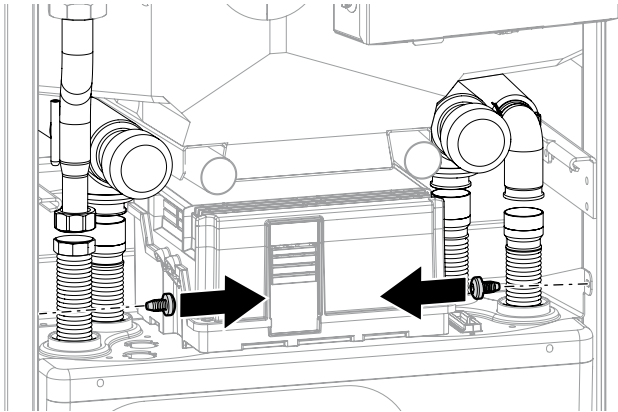

12. To protect the floor and move the module box (3) more easily: place boards (4) under it, e.g. from the packaging material.

13. Lift and hold nut (1) on the heating flow.

14. Slowly and carefully pull out the module box by the retaining loops (2). Ensure that none of the pipes are damaged

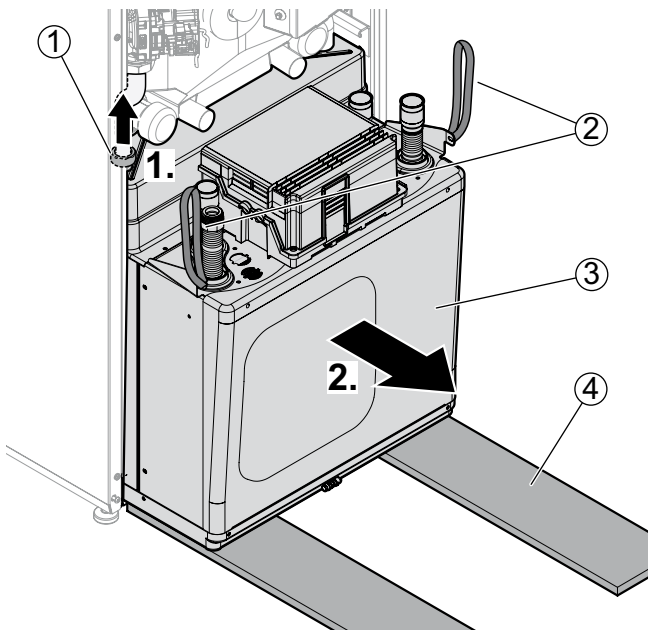

15. Pull out the module box completely and place it on the boards.

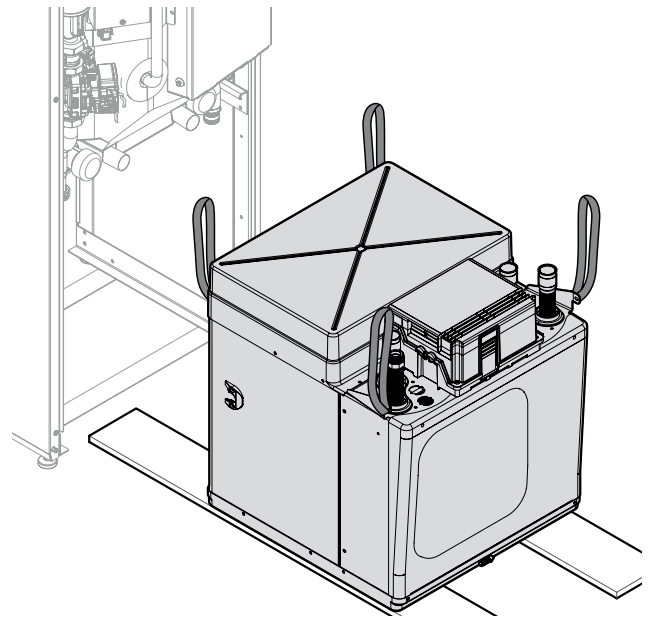

6.2 Installing the module box

1. Place the module box carefully in the bottom in the heating station and slowly and carefully push it in.
 - At the same time, lift and hold the nut on the heating flow.
 - Ensure that none of the pipes are damaged.
2. Attach the two side retaining screws.
3. Connect the heating flow and hydraulic connections. At the same time, replace O-rings on the heat pump connections (→ separate pack included).
4. Perform pressure test and insulate pipes with the enclosed insulation hoses (→ separate pack).
5. Connect the electrical connections.
 - Plug in 2 white connectors at the bottom of the electrical control cabinet. Ensure that the connectors move easily and the lugs latch into position.
 - Plug in the black rectangular connector at the top of the module box.



6.3 Install the hydraulic connections

ATTENTION

Damage to the copper pipes due to unacceptable loading!

- ▶ Secure all connections against twisting.



NOTE

The heat source can be connected from the top, right or left.

- ✓ The heat source system has been installed in accordance with the specifications (→ planning & design manual, dimensioned diagrams, installation plans).
- ✓ Cross-sections and lengths of the pipes for the heating circuit and heat source are dimensioned adequately.
- ✓ The free pressure of the circulation pumps produces at least the minimum throughput required for the unit type (→ “Technical data/Scope of supply” on page 24).
- ✓ The cables for the heat source and the heating are fixed to the wall or ceiling via a fixed point.

Install the compression fittings and ball valves

ATTENTION

Leaks or fracture of the union nut due to excessive force!

- ▶ Tighten the union nut only as far as described here.
1. Check pipe ends for scratches, dirt and deformation.
 2. Check proper position of the clamping ring on the fitting.
 3. Push the pipe through the clamping ring up to the limit stop in the fitting.
 4. Tighten the union nut hand-tight and attach waterproof marking.
 5. Tighten union nut with 3/4 rotation.
 6. Check connection for leaks.

If the connection leaks:

1. Undo connection and check pipe for damage.
2. Tighten the union nut hand-tight and retighten with the open-ended spanner with 1/8 to 1/4 turn, as the clamping ring is already in a clamping position.

Connect the unit to the heat source, domestic water pipes and heating circuit

1. Install shut-off devices in the heating circuit.
2. Insert the vent at the highest point of the heat source and the heating circuit.
3. Recommendation: Fit a dirt filter with mesh size 0.9 mm onto the heat source inlet.
4. Connect the domestic hot water tank according to the local regulations.
5. Recommendation: To balance out pressure fluctuations and water hammers and avoid unnecessary loss of water, install an expansion vessel with through-flow fitting.
6. Ensure that the operating overpressures (→ “Technical data/Scope of supply” on page 24) are not exceeded. Install pressure reducer if necessary.

6.4 Connect the electrical cables

ATTENTION

Irreparable damage to the compressor due to wrong rotating field!

- ▶ Ensure that there is a clockwise rotating field for the compressor load infeed.



Basic information on the electrical connection



NOTE

Ensure that the unit is supplied with electricity at all times. After working inside the unit and attaching the unit panelling, switch the power supply back on immediately.

- The specifications of the local power supply company may apply to electrical connections.
- Fit the power supply for the heat pump with an all-pole miniature circuit-breaker with at least 3 mm contact spacing (IEC 60947-2).
- Note the level of the tripping current (→ “Technical data/Scope of supply” on page 24).
- Comply with the electromagnetic compatibility regulations (EMC regulations).
 - Lay the control/sensor cables and unit supply cable sufficiently far apart (> 100 mm).
 - Lay unshielded power supply cables and shielded cables (LIN bus cable) with sufficient distance between them.
- Do not lengthen the patch cable and LIN bus cable. LIN bus cables up to 30 m long can be used.

Pull in the cables and conductors and make the connections

1. Strip the sheathing of electrical cables before laying in the cable duct of the control box.
2. Open electrical switchbox:
 - Undo 2 screws at the top of the cover panel of the electrical control box.
 - Unhook cover panel.

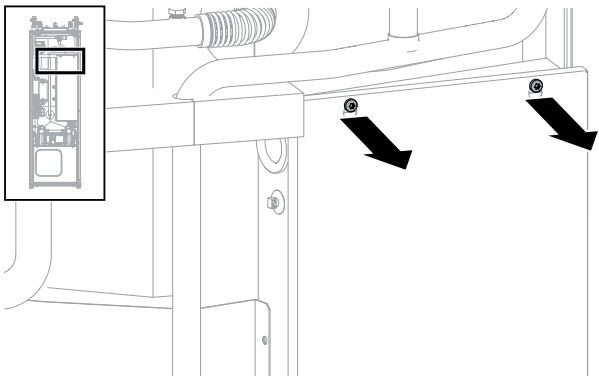

3. Lay the control / sensor cables and unit supply cable and connect:

- Route cables through the reserve conduits (1) and (2) only, from above into the inside of the unit.
- Route cables from underneath through the cable openings in the control box (3).

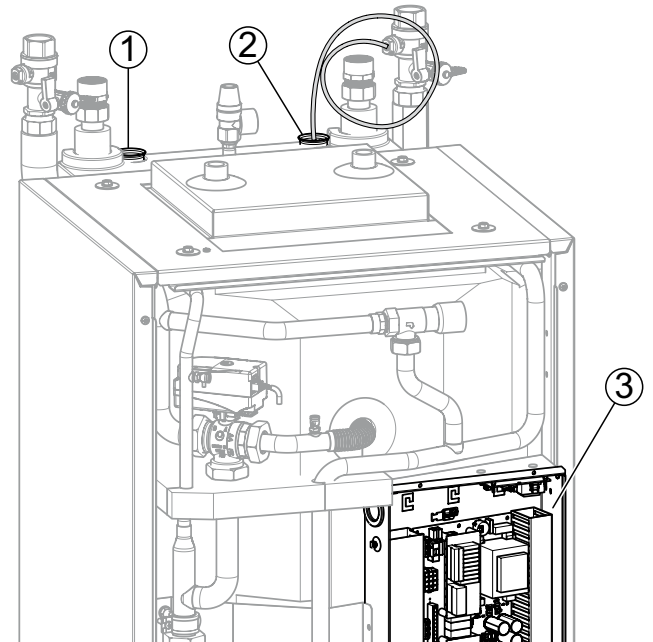

- Connect cables to the respective terminals (→ “Terminal diagram” on page 38).

Control the controller via a PC

1. During installation lay a shielded network cable (category 6) through the unit.
2. Plug the RJ-45 connector of the network cable into the bush of the control unit (1).

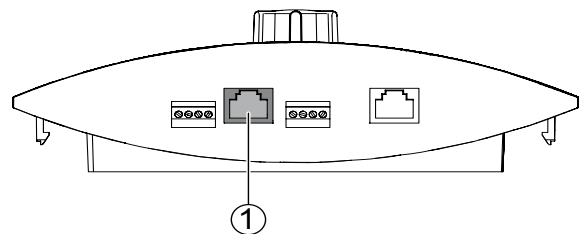

NOTE

The network cable can be retrofitted at any time. To do this, dismantle the masking plate.



6.5 Installing the control unit



NOTE

The control unit can be inserted in a recess in the front panel of the unit or can be installed on the wall.

Insert the control unit in the unit and connect

1. If required: Remove masking plate from the slot provided. To do this, press the latching lugs together and push out of the openings.
2. Remove film from the plastic element of the front panel.
3. Position the control unit in the recess in the front panel of the unit and press the latching lugs into the openings.

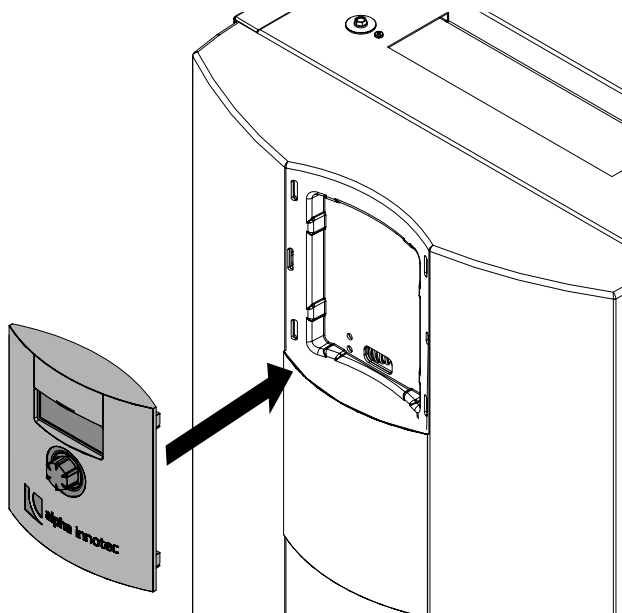

4. Cut the cable to length generously so that the front panel can be removed and placed to the side of the unit. Do not cut the cable ties for strain relief of the LIN bus cable at the electric control box.
 - LIN bus cable approx. 1.1 m from the fixing of the strain relief at the electrical control box
 - All other cables approx. 1.2 m
5. Use cable ties to fix the LIN bus cable to a web of the cover around 20 cm in front of the connector (strain relief).
6. Push the cable through the opening in the front panel of the unit from below and into the control unit.
7. Insert cover in the free slot.

Mount the control unit on the wall and connect

1. Release the rear bracket from the control unit.
2. Cut off latching lugs (if visually obtrusive).
3. Mark 2 drillholes (→ “Dimensioned drawing of control unit, wall-mounted bracket” on page 29).
4. Fix the wall-mounted bracket (2) with 2 wallplugs (1) and 2 screws (3).

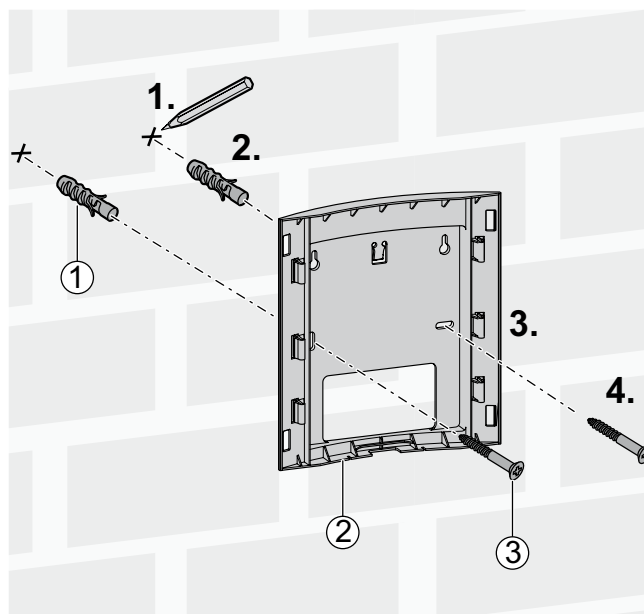

5. Feed in the cables from the wall (e.g. in-wall box) or from below.
6. Push the control unit onto the wall-mounted bracket.
7. Route the LIN bus cable from the top right-hand side at the rear from the heat pump and plug into the control unit at the bottom.
8. Push on cover. If applicable, position second cover (accessories) on the second unused slot.



7 Flushing, filling and venting

7.1 Remove the front panel of the module box

- ▶ Unscrew the front panel of the module box.

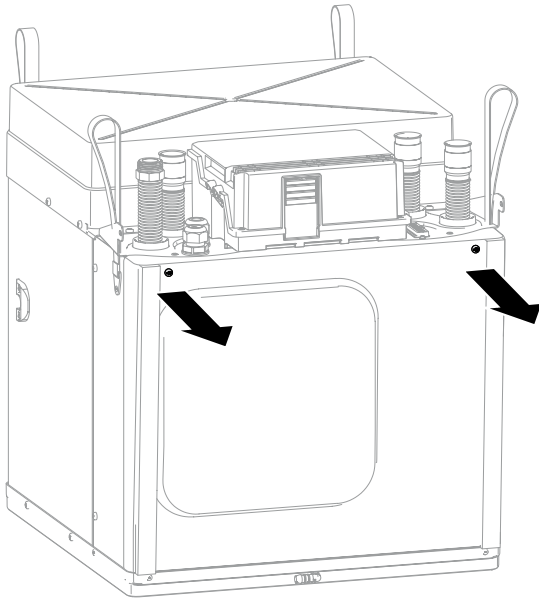

7.2 Heating water quality



NOTE

- For detailed information refer, among other things, to the VDI Guidelines 2035 “Vermeidung von Schäden in Warmwasserheizanlagen” (preventing damage in hot water heating systems).
 - Required pH value: 8.2 ... 10
 - for aluminium materials: pH value: 8.2 ... 8.5
- ▶ Fill the system with deionised heating water (VE water) only (low-salt operation of the system).

Advantages of low-salt operation:

- Low corrosion-promoting properties
- No formation of mineral scale
- Ideal for closed heating circuits
- ideal pH value due to self-alkalinisation after filling the system
- If necessary, simple alkalinisation to pH value 8.2 by adding chemicals

7.3 Fill, flush and vent heat source

Water and the following antifreeze products are approved for filling the brine circuit:

- Monopropylene glycol
 - Monoethylene glycol
 - Ethanol
 - Methanol
- ▶ For operation of the heat source with water or water-antifreeze mixture, ensure that the water fulfils the quality specifications of the heating water side.
 - ▶ Check that frost protection to -13 °C is ensured.
 - ▶ Ensure that the antifreeze is compatible with the pipe, seal and other component materials used on site.
- ✓ Drain pipe of the safety valve is connected.
 - ✓ Room is ventilated.
1. Flush heat source system.
 2. Mix antifreeze with water thoroughly with the required ratio, before adding to the heat source.
 3. Check the concentration of the water-antifreeze mixture. Frost protection: -13 °C
 4. Fill the heat source with the water-antifreeze mixture.
 5. Flush until the system is air-free.



7.4 Vent the circulation pump of the heat source



NOTE

The diagram shows the unit variant with cooling. In the unit variant without cooling the circulation pump is located in the same place.

1. Place vessel for collecting discharging liquid under the outlet.
2. Undo screw-on cap in the middle of the circulation pump.

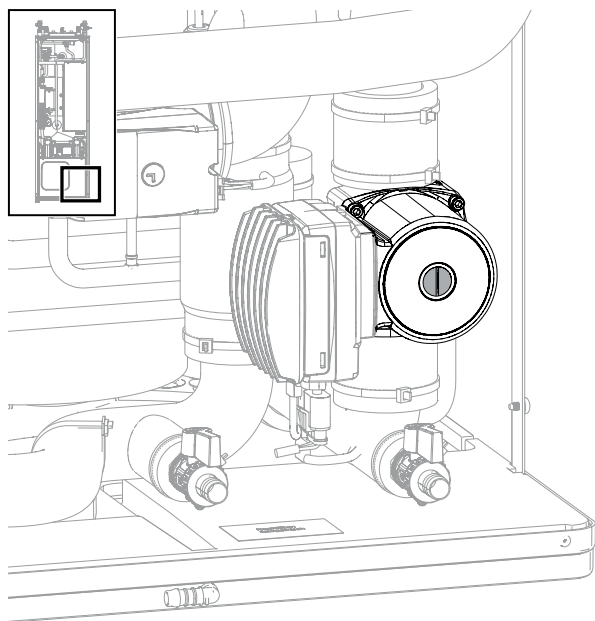

3. Wait until liquid is discharged uniformly.
4. Screw the cap back on tightly.
5. Unscrew the front panel of the module box.
6. Dispose of collected liquid according to the local regulations.
7. Set system pressure to 1 bar.

7.5 Flush and fill the heating and domestic hot water charge circuit

- ✓ Drain pipe of the safety valve is connected.
 - ▶ Ensure that the set pressure of the safety valve is not exceeded.
1. Pull the U-clip (2) off the floor of the valve motor (1).
 2. Pull the valve motor carefully upwards and off the 3-way changeover valve (3).

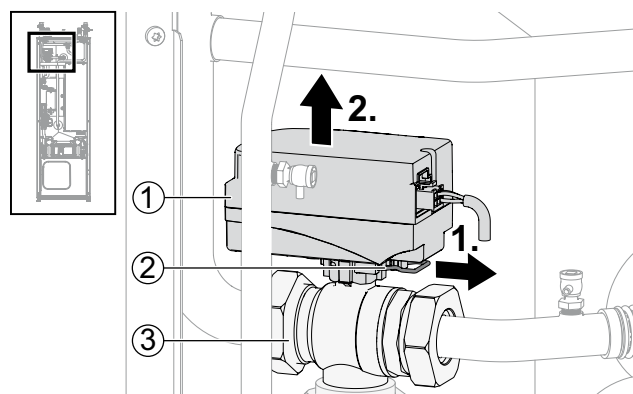

3. Turn the spindle of the 3-way changeover valve so that the rounded side of the spindle points in the direction of marking A of the connections of the 3-way changeover valve.

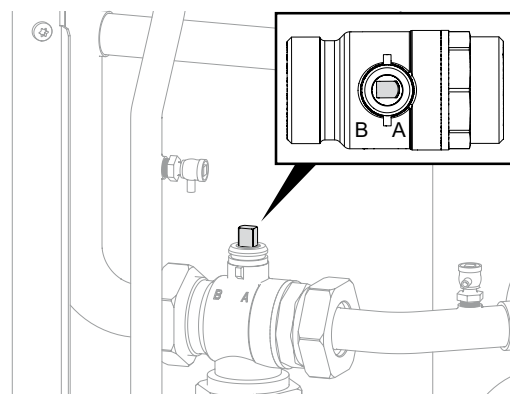

4. Flush the domestic hot water charge circuit for approx. 1 minute.
5. Turn the spindle so that the rounded side of the spindle points in the direction of marking B of the connections of the 3-way changeover valve.
6. Flush heating circuit thoroughly, until no more air is discharged.
7. Position the valve motor (1) on the 3-way changeover valve (3).



8. Insert the U-clip (2) into the floor of the valve motor.

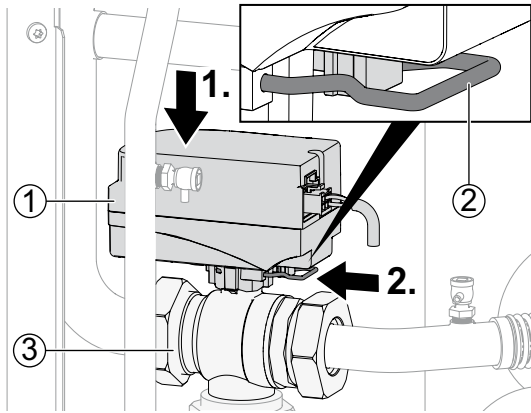

9. Ensure that the U-clip has latched into position correctly:
 - Valve motor sits securely on the 3-way changeover valve.
 - Both prongs of the U-clip sit on the lug.
 - The tips of the U-clip are visible by approx. 2 mm (not significantly more!).

7.6 Flush, fill and vent the domestic hot water tank

- ✓ Drain pipe of the safety valve is connected.
 - ▶ Ensure that the set pressure of the safety valve is not exceeded.
1. Open the domestic water inlet valve at the domestic hot water tank.
 2. Open taps for domestic hot water.
 3. Flush the domestic hot water tank until no more air discharges from the valves at the taps.
 4. Close taps for domestic hot water.

8 Insulate hydraulic connections

1. Insulate heating circuit, heat source and domestic water pipes according to the local regulations.
2. Open shut-off devices.
3. Perform a pressure test and check for leaks.
4. Insulate the internal piping of the module box with the insulation material from the separate pack included.
5. Insulate external piping on site.
6. Insulate all connections, fittings and pipes.
7. Insulate heat source so that it is vapour-diffusion tight.
8. Insulate the heating circuit of units with cooling vapour-diffusion tight too.

9 Set the overflow valve



NOTE

- The activities in this section are only necessary for in-line tank integration.
 - Complete the worksteps quickly, otherwise the maximum return temperature can be exceeded and the heat pump switches to high-pressure fault.
 - Turn the adjusting knob at the overflow valve to the right to increase the temperature difference (the temperature drop), turn it to the left to reduce it.
- ✓ System is running in heating mode (ideally in cold condition).

In the IBN Wizard it is possible to set the overflow valve according to the hydraulic system for integration of storage tanks connected in series.

Startup guide Set bypass valve?



Confirm IBN Wizard or make the setting via:

Service >> Settings >> Efficiency pump

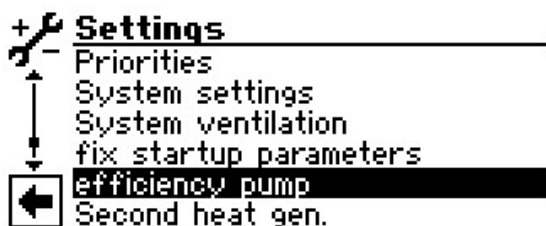

The „Set overflow valve“ menu item is pre-set to „No“. The overflow valve setting function is deactivated.

- Control signal UWP is the display of the currently requested pump delivery in %
- Actual flow is the current flow (measuring accuracy +/- 200l/h)

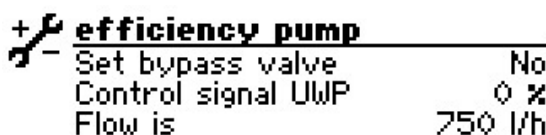

- ▶ Open the overflow valve fully, close heating circuits
- ▶ Switch the „Set overflow valve“ menu item from No“ to „Yes“; the circulation pump is then activated with 100% – the pump starts up.
- ▶ If the control signal UWP 100% has been reached, close the changeover valve so that the nominal flow can be ensured (see technical data).

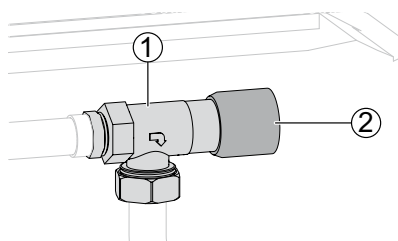

overflow valve (1) adjusting knob (2)

- ▶ After leaving the „Set overflow valve“ menu or after 1 hour at the latest the circulation pump switches back to default control
- ▶ Valves for heating open

10 Commissioning



NOTE

The first filling and initial startup of the domestic hot water tank must be carried out by qualified personnel.

- ✓ Relevant planning & design data of the system is documented in full.
 - ✓ The competent energy supplier has been notified of operation of the heat pump system.
 - ✓ System is air-free.
 - ✓ Installation check using the general checklist has been completed successfully.
1. Ensure that the following points are fulfilled completely:
 - Right-hand (clockwise) rotating load infeed field is available at the compressor.
 - Heating station is installed and mounted according to this operating manual.
 - The electrical installation has been carried out properly according to this operating manual and local regulations. The power supply for the heat pump is equipped with an all-pole miniature circuit-breaker with at least 3 mm contact spacing (IEC 60947-2).
 - The level of the tripping current is compliant.
 - The heating circuit and heat source are flushed and vented.
 - The frost protection of the heat source liquid is at -13 °C.
 - All shut-off devices of the heating circuit are open.
 - All shut-off devices of the heat source are open.
 - The pipe systems and components of the system are leaktight.
 2. Fill out carefully and sign the completion report for heat pump systems.
 3. In Germany and Austria: Send completion report for heat pump systems and general checklist to the manufacturer's factory customer service department. In other countries: Send completion report for heat pump systems and general checklist to the manufacturer's local partner.
 4. Arrange for the heat pump system to be started up by customer service personnel authorised by the manufacturer; this is a chargeable service.
 5. Ensure that the water supply to the domestic hot water tank is open.



11 Maintenance



NOTE

We recommend that you sign a maintenance agreement with an accredited heating company.

11.1 Basic principles

The cooling circuit of the heat pump requires no regular maintenance.

Local regulations— e.g. EU Regulation (EC) 842/2006 – among other things, require leak checks beforehand and/or for a logbook to be kept for certain heat pumps.

The hermetic leaktightness and refrigerant fill quantity are criteria for whether a logbook has to be kept and leak tests performed or not, and at what time intervals.

- ▶ Ensure compliance with local regulations with regard to the specific heat pump system.

11.2 Maintenance as required

- Yearly, more frequently if necessary:
 - Checking and cleaning the components of the heating circuit and the heat source, e.g. valves, expansion vessels, circulation pumps, filters, dirt traps.
 - Checking the function of the safety valve (on site) for the domestic hot water tank and the safety valve for the heating circuit.

11.3 Yearly maintenance

- ▶ Record the quality of the heating water analytically. In case of deviations from the specifications, take suitable measures without delay.

Clean unit variant with SVGW storage tank (SVGW: Swiss gas and water association (Schweizerischer Verein des Gas- und Wasserverbands)):

1. Drain the domestic hot water tank via the drain valve at the domestic cold water inlet.
2. Vent the domestic hot water tank and pipes via the hot water taps in the apartments.
3. Check the domestic hot water tank and clean via the cleaning opening on the underside of the tank.
4. After cleaning and testing, refill the domestic hot water tank.
5. Vent the domestic hot water tank and pipes via the hot water taps in the apartments.

11.4 Clean and flush the evaporator and condenser

- ▶ Clean and flush the evaporator/condenser strictly according to the manufacturer's regulations.
- ▶ After flushing the evaporator/condenser with chemical cleaning product: Neutralise any residues and flush the evaporator/condenser thoroughly with water.

12 Faults



NOTE

If the safety temperature limiter on the electric heating element has tripped, no fault is displayed.

- ▶ Read out the cause of the fault via the diagnostics program of the heating and heat pump controller.
- ▶ Contact the local partner of the manufacturer or the factory's customer service. Have the fault message and unit number (→ "Unit sticker" on page 3) to hand.

12.1 Unlock the safety temperature limiter

A safety temperature limiter is installed in the electric heating element. If the heat pump fails or there is air in the system:

- ▶ Check whether the Reset button (1) of the safety temperature limiter (2) has jumped out (by approx. 2 mm).

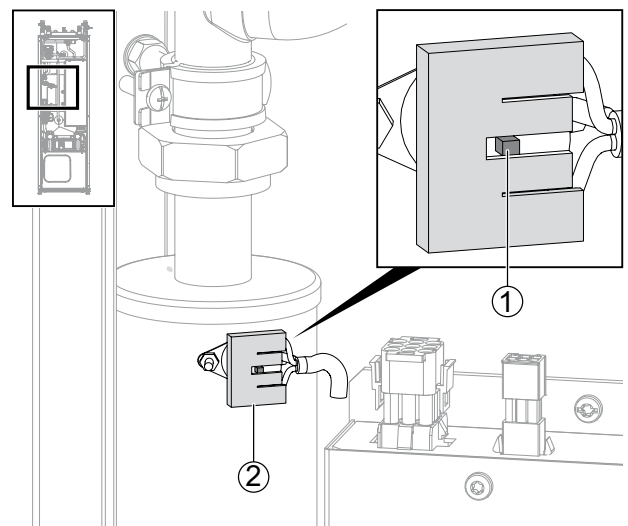

- ▶ Press the reset button back in again.



- ▶ If the safety temperature limiter trips again, contact the local partner of the manufacturer or the factory's customer service.

13 Dismantling and Disposal

13.1 Dismantling

- ✓ Unit is safely disconnected from the power supply and protected against being switched back on again.
- ▶ Collect all media safely.
- ▶ Separate components by their materials.

13.2 Disposal and Recycling

- ▶ Dispose of media harmful to the environment according to local regulations, e.g. antifreeze mixture, refrigerant.
- ▶ Recycle or ensure proper disposal of unit components and packaging materials according to local regulations.

Buffer (standby) battery

1. Use a screwdriver to push out the buffer battery on the processor board of the control unit

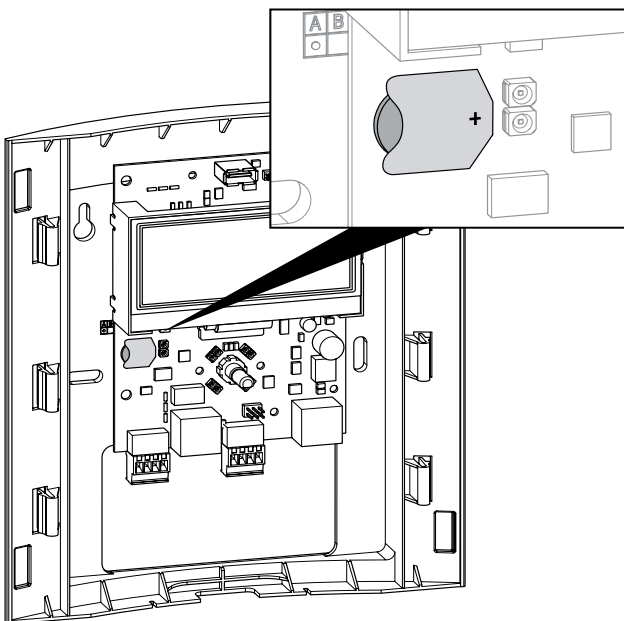

2. Dispose of the buffer battery according to local regulations.



Technical data/Scope of supply

Performance data				WZSV 62(H)(K)3M	WZSV 162(H)(K)3M
Heating capacity COP	for B0/W35 to EN14511	Partial load operation	kW COP	3,32 4,86	9,42 4,92
	for B0/W45 to EN14511	Partial load operation	kW COP	3,09 3,76	9,15 3,85
	for B0/W55 to EN14511	Partial load operation	kW COP	2,95 3,13	9,06 3,22
	for B7/W35 flow of B0/W35	Partial load operation	kW COP	4,18 5,94	11,31 6,05
Heating capacity	for B0/W35	min. max.	kW kW	2,00 6,25	4,19 17,21
	for B0/W45	min. max.	kW kW	1,80 5,50	3,37 16,97
	for B0/W55	min. max.	kW kW	1,56 5,17	3,24 17,01
	for B7/W35	min. max.	kW kW	2,40 8,15	5,25 20,20
Cooling capacity at max. volume flow (B15/W25), units with passive cooling: Identifier K:			kW	6,7	8,8
Limits of use					
Heating circuit return min. Heating circuit flow max.			°C	20 65	20 65
Heat source		min. max.	°C	-5 25	-5 25
Additional operating points			...	—	—
Sound					
Sound pressure level at 1m distance from edge of unit		min. max.	dB(A)	29 36	29 36
Sound power level to EN12102		min. max.	dB(A)	44 51	44 51
Heat source					
Volume flow: minimum nominal analogue B0W35 (50Hz) maximum			l/h	450 740 1800	750 2350 4100
Max. free heat pump pressure Δp (with cooling Δp_K ***) Volume flow			bar (bar) l/h	0,76 (0,72) 740	0,88 (0,80) 2350
Approved anti-freeze			Monoethylene glycol Propylene glycol Methanol Ethanol	• • • •	• • • •
Anti-freeze concentration: Minimum frost protection down to			°C	-13	-13
Max. allowable operating pressure			bar	3	3
Heating circuit					
Volume flow: minimum nominal analogue B0W35 (50Hz) maximum			l/h	260 520 1350	550 1600 3000
Max. free heat pump pressure Δp (with cooling Δp_K) Volume flow			bar bar l/h	0,74 (0,70) 520	0,54 (0,50) 1600
Max. allowable operating pressure			bar	3	3
General unit data					
Total weight (with cooling)			kg	240 (248)	275 (283)
Box weight (with cooling) Tower weight (with cooling)			kg (kg) kg (kg)	80 (88) 160 (160)	115 (123) 160 (160)
Refrigerant type Refrigerant capacity			... kg	R407c 1,16	R407c 2,20
Domestic hot water tank					
Net volume			l	178	178
Impressed current anode			integrated: • yes — no	•	•
Domestic hot water temperature, heating pump mode Electric heating element			up to °C	58 65	58 65
Mixed water quantity according to ErP: 2009/125/EC (at 40°C, draw-off of 10 l/min)			l	270	270
Standing loss according to ErP: 2009/125/EC (at 65°C)			W	60	60
Maximum pressure			bar	10	10
Electrics					
Voltage code all-pole heat pump fusing *)**)			... A	—	3~N/PE/400V/50Hz C10
Voltage code all-pole heat pump fusing *) + electric heating element **)				3~N/PE/400V/50Hz C16	—
Voltage code Control voltage fusing **)			... A	1~N/PE/230V/50Hz B10	1~N/PE/230V/50Hz B10
Voltage code Electric heating element fusing **)			... A	—	3~N/PE/400V/50Hz B16
WP*): effect. Power input B0/W35 (50Hz) EN14511 Power consumption I cos ϕ			kW A ...	0,67 3,0 0,95	1,91 2,6 0,60
WP*): effective power input B0/W35 to EN14511: min. max.			kW kW	0,49 2,10	0,82 4,75
WP*): Max. machine current Max. power input within the limits of use			A kW	12 2,6	10 7,3
Starting current: direct with soft starter			A A	< 5 —	< 5 —
Degree of protection			IP	20	20
Electric heating element output			kW	6 3	9 6 3
Circulation pump power consumption, heating circuit heat source			min. — max. W W	2 – 60 5 – 87	2 – 60 3 – 180
Other unit information					
Safety valve, heating circuit Heat source		included in scope of supply: • yes — no		• —	• —
Expansion valve, heating circuit Heat source		included in scope of supply: • yes — no		— —	— —
Overflow valve Changeover valve		integrated: • yes — no		• •	• •
Vibration isolators, heating circuit Heat source		integrated: • yes — no		• •	• •
*) Only compressor, **) Follow local regulations, ***) Figures for 25% mono-ethylene glycol				813486a	813489a





Performance curves

WZSV 62(H)(K)3M

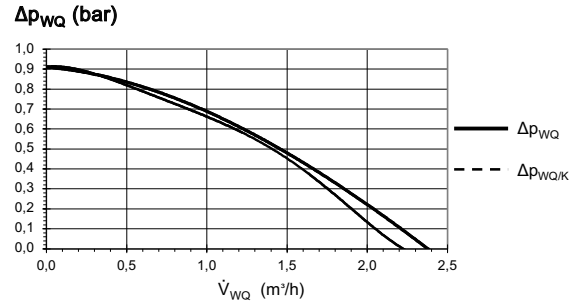
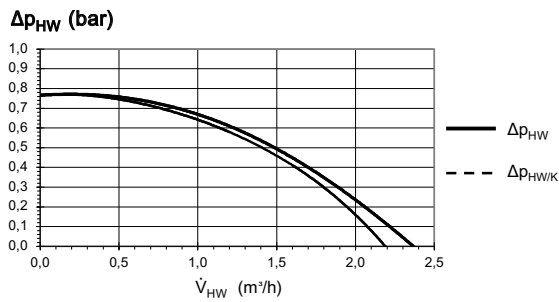
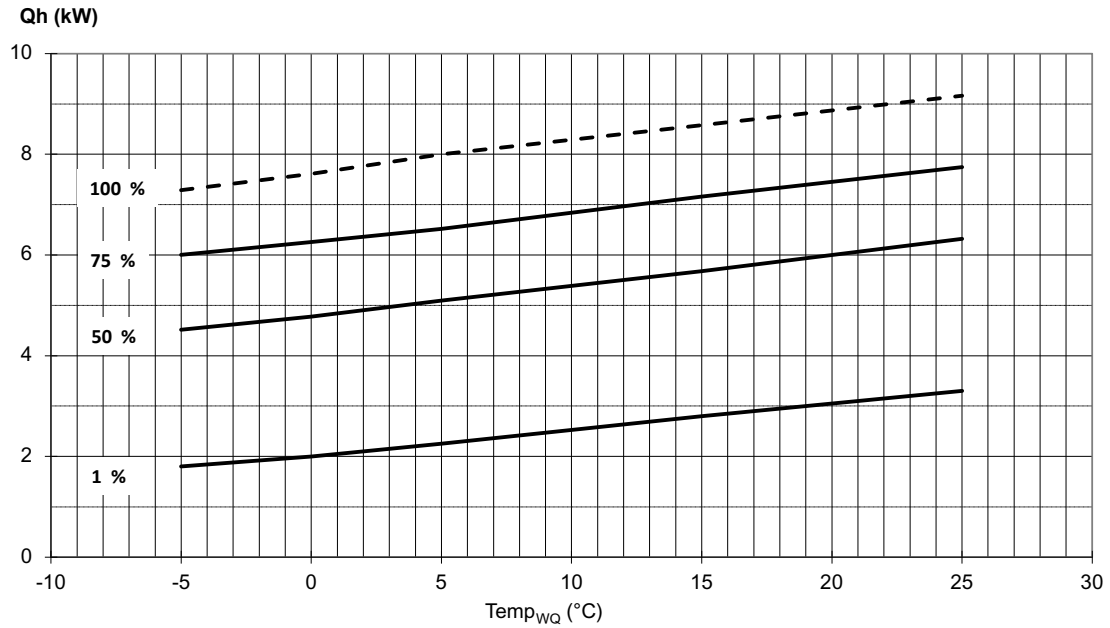

823255

Key:	DE823000L/170408
\dot{V}_{HW}	Heating water volume flow rate
\dot{V}''	Heat source volume flow rate
$Temp_{WQ}$	Heat source temperature
Q_h	Heating capacity
P_e	Power consumption
COP	Coefficient of performance
$\Delta p_{HW} / \Delta p_{HW/K}$	Heating circuit free pressure / Heating circuit with cooling free pressure
$\Delta p_{WQ} / \Delta p_{WQ/K}$	Heat source free pressure / Heat source with cooling free pressure



WZSV 162(H)(K)3M

Performance curves

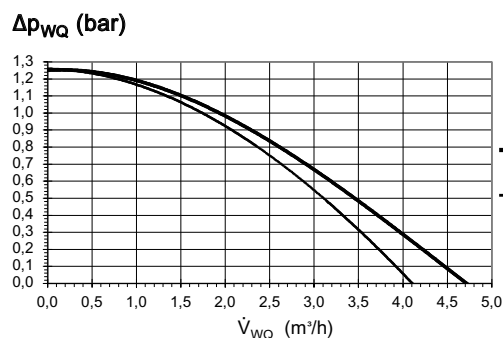
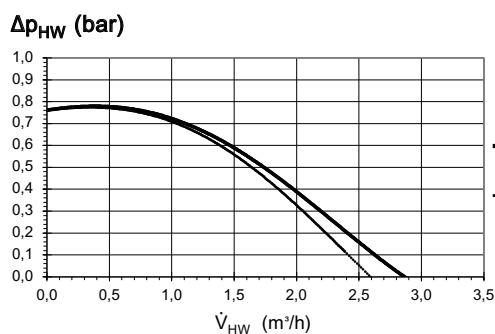
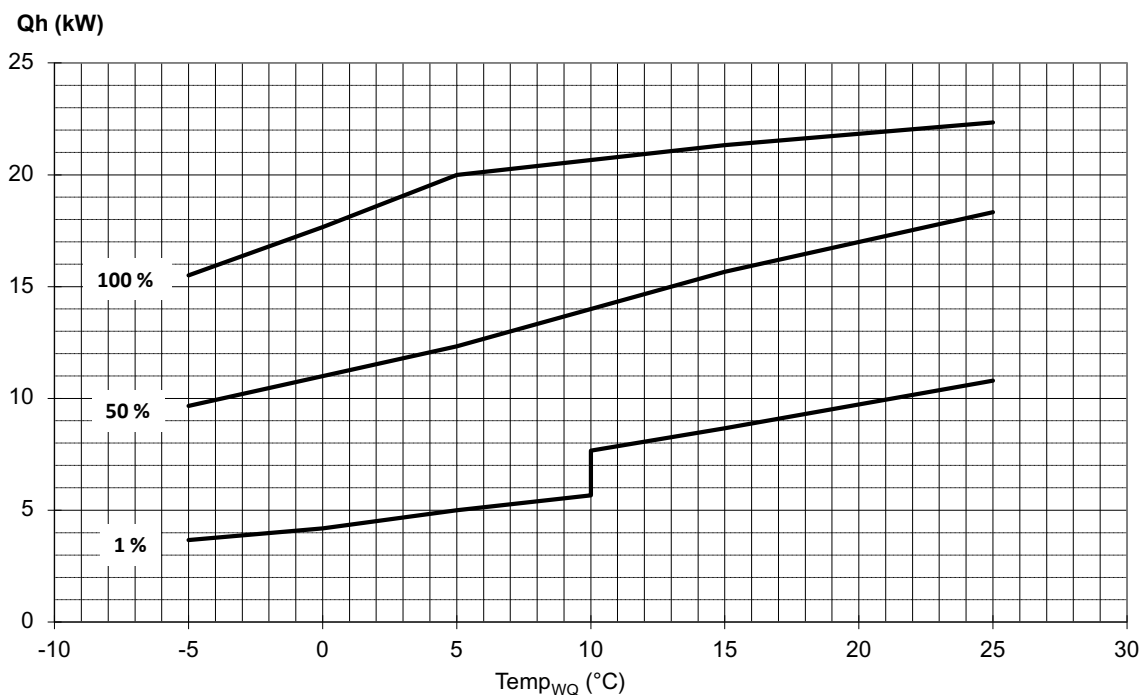

- Key: DE823000L/170408
- \dot{V}_{HW} Heating water volume flow rate
 - \dot{V}'' Heat source volume flow rate
 - $Temp_{wQ}$ Heat source temperature
 - Q_h Heating capacity
 - P_e Power consumption
 - COP Coefficient of performance
 - $\Delta p_{HW} / \Delta p_{HW/K}$ Heating circuit free pressure / Heating circuit with cooling free pressure
 - $\Delta p_{wQ} / \Delta p_{wQ/K}$ Heat source free pressure / Heat source with cooling free pressure



Dimensioned drawings

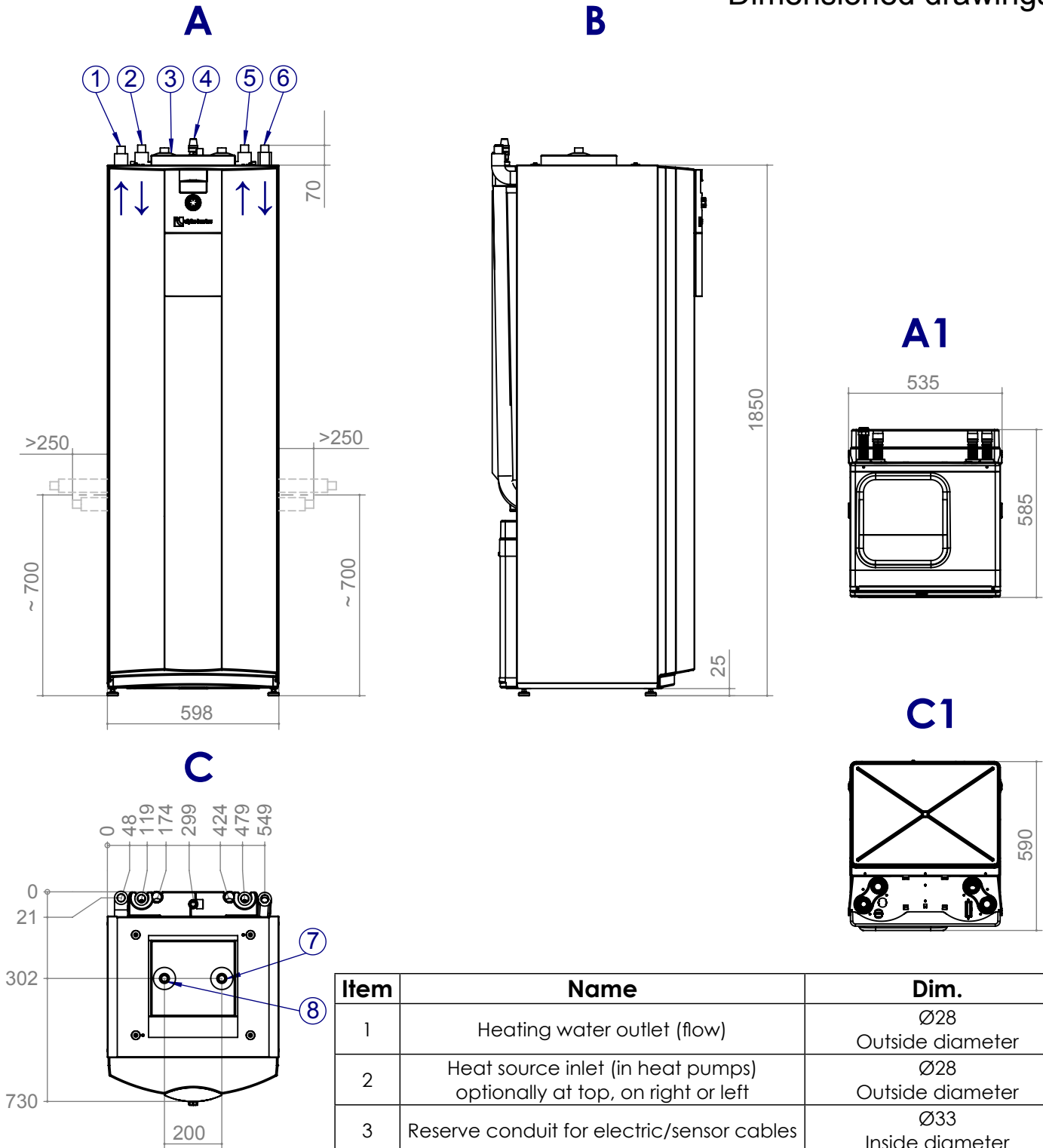

Key: D819447
 All dimensions in mm.

- A Front view
- B Side view from left
- C Plan view
- A1 Front view of module box
- C1 Top view of module box

Item	Name	Dim.
1	Heating water outlet (flow)	Ø28 Outside diameter
2	Heat source inlet (in heat pumps) optionally at top, on right or left	Ø28 Outside diameter
3	Reserve conduit for electric/sensor cables	Ø33 Inside diameter
4	Heating circuit safety valve (in the separate package)	Rp 3/4" internal thread
5	Heat source outlet (from heat pump) optionally at top, right or left	Ø28 Outside diameter
6	Heating water inlet (return)	Ø28 Outside diameter
7	Domestic hot water	R 3/4" external thread
8	Cold domestic water	R 3/4" external thread



Dimensioned drawing of control unit, wall-mounted bracket

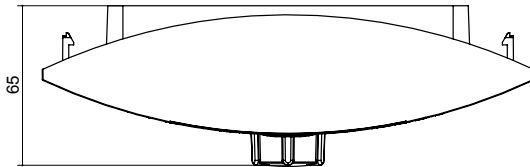
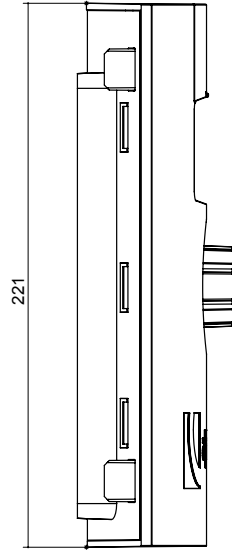
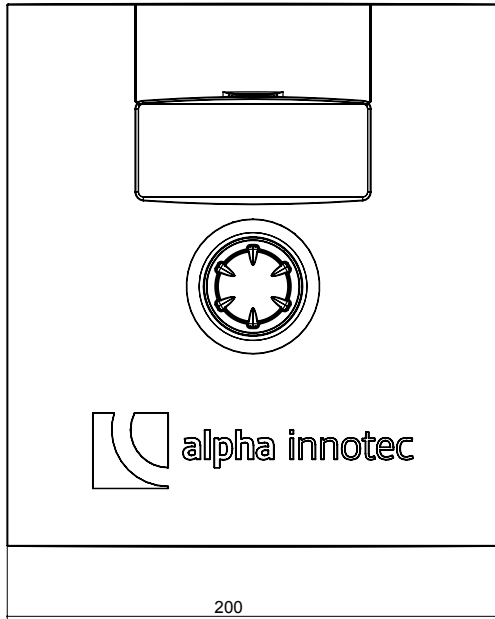

Wall mounted

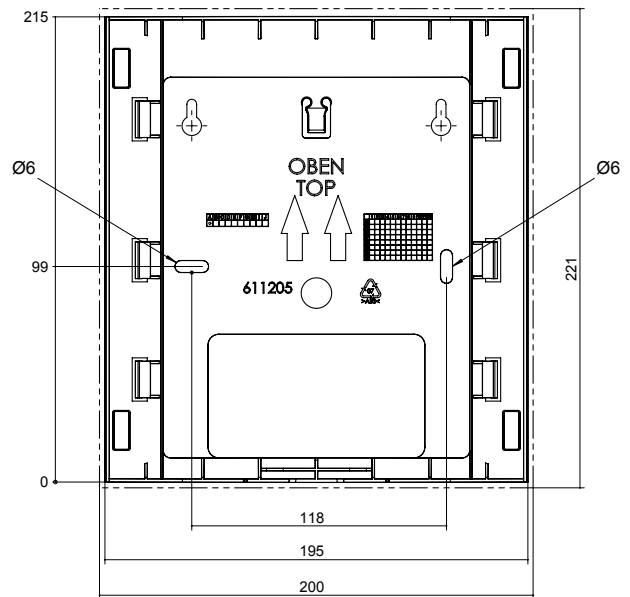



Installation plans

V1

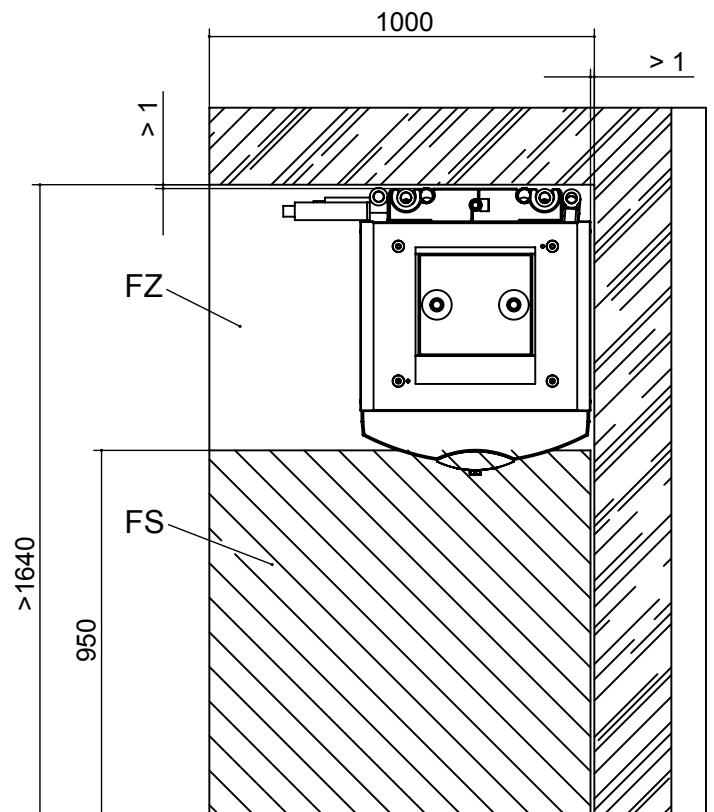
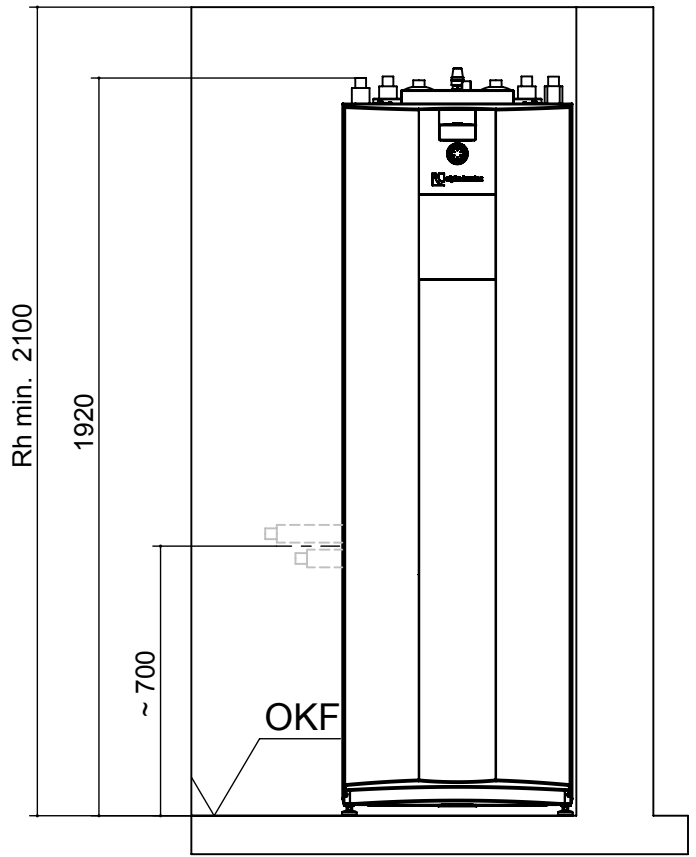

Key: DE819448

V1 Version 1

Rh min. Minimum room height

FS Free space for service purposes

FZ Free space for functionally necessary accessories

OKF Finished floor level

?

All dimensions in mm.



Installation plans

V2

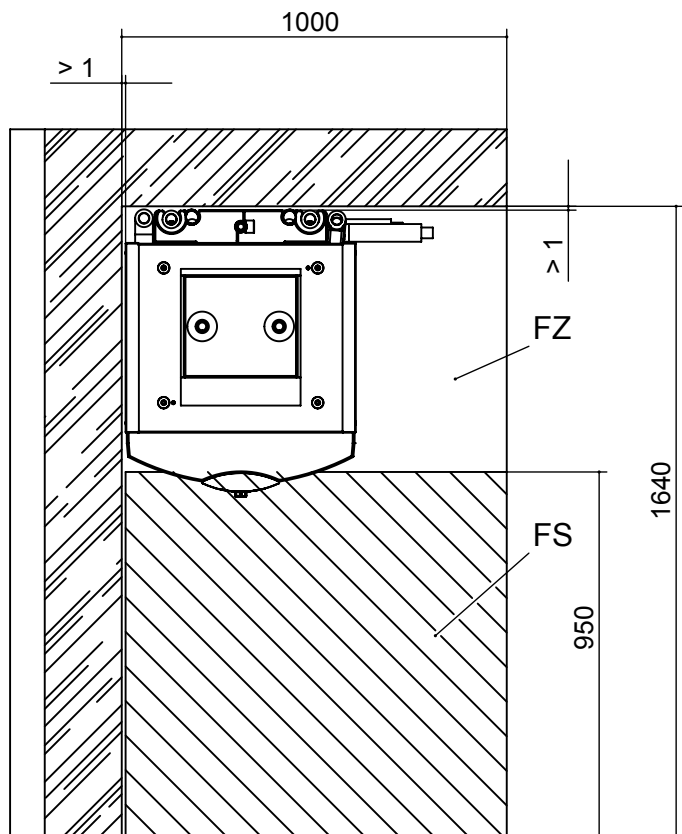
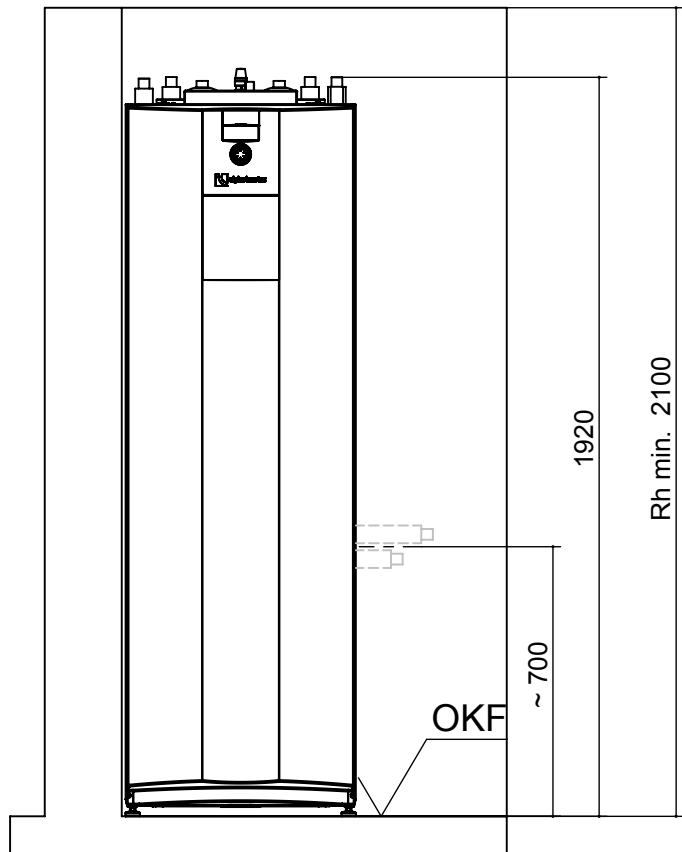

Key: DE819448

V1 Version 2

Rh min. Minimum room height

FS Free space for service purposes

FZ Free space for functionally necessary accessories

OKF Finished floor level

All dimensions in mm.



Installation plans

V3

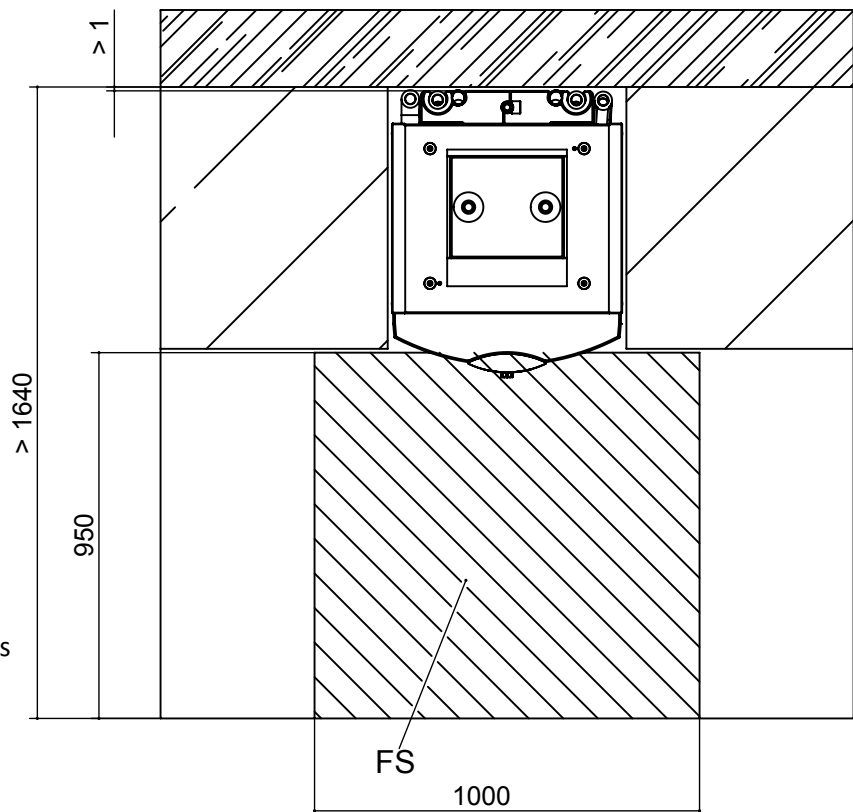
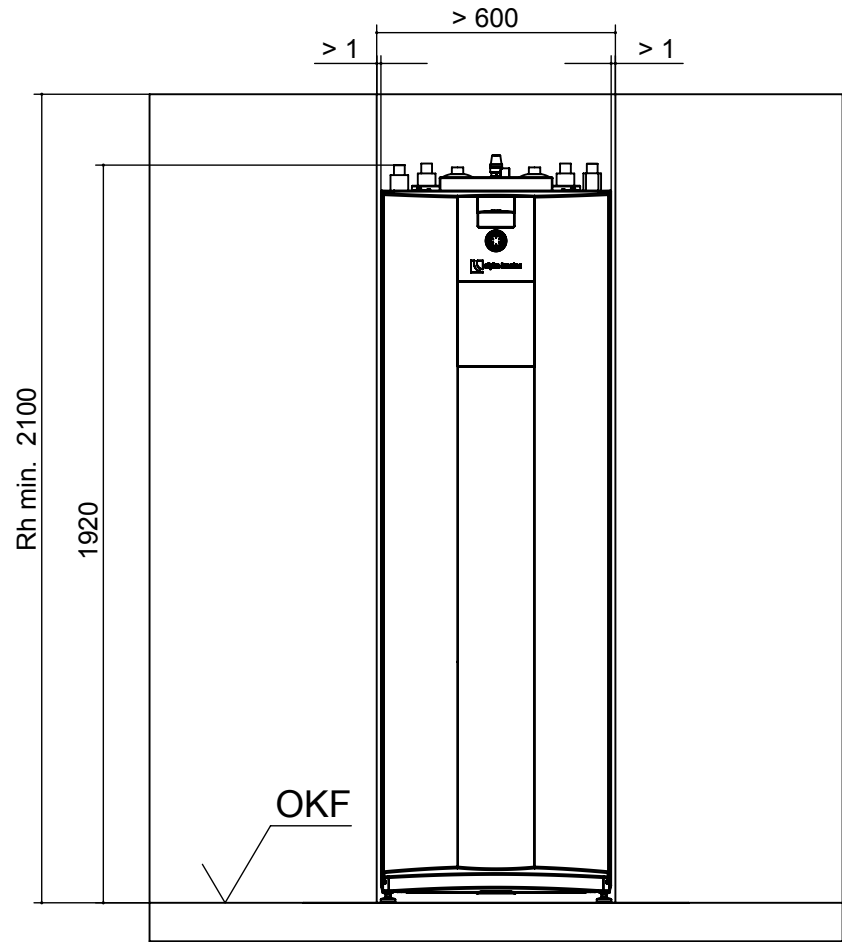

Key: DE819448

V3 Version 3

Rh min. Minimum room height

FS Free space for service purposes

OKF Finished floor level

All dimensions in mm.



Hydraulic integration, separate buffer tank

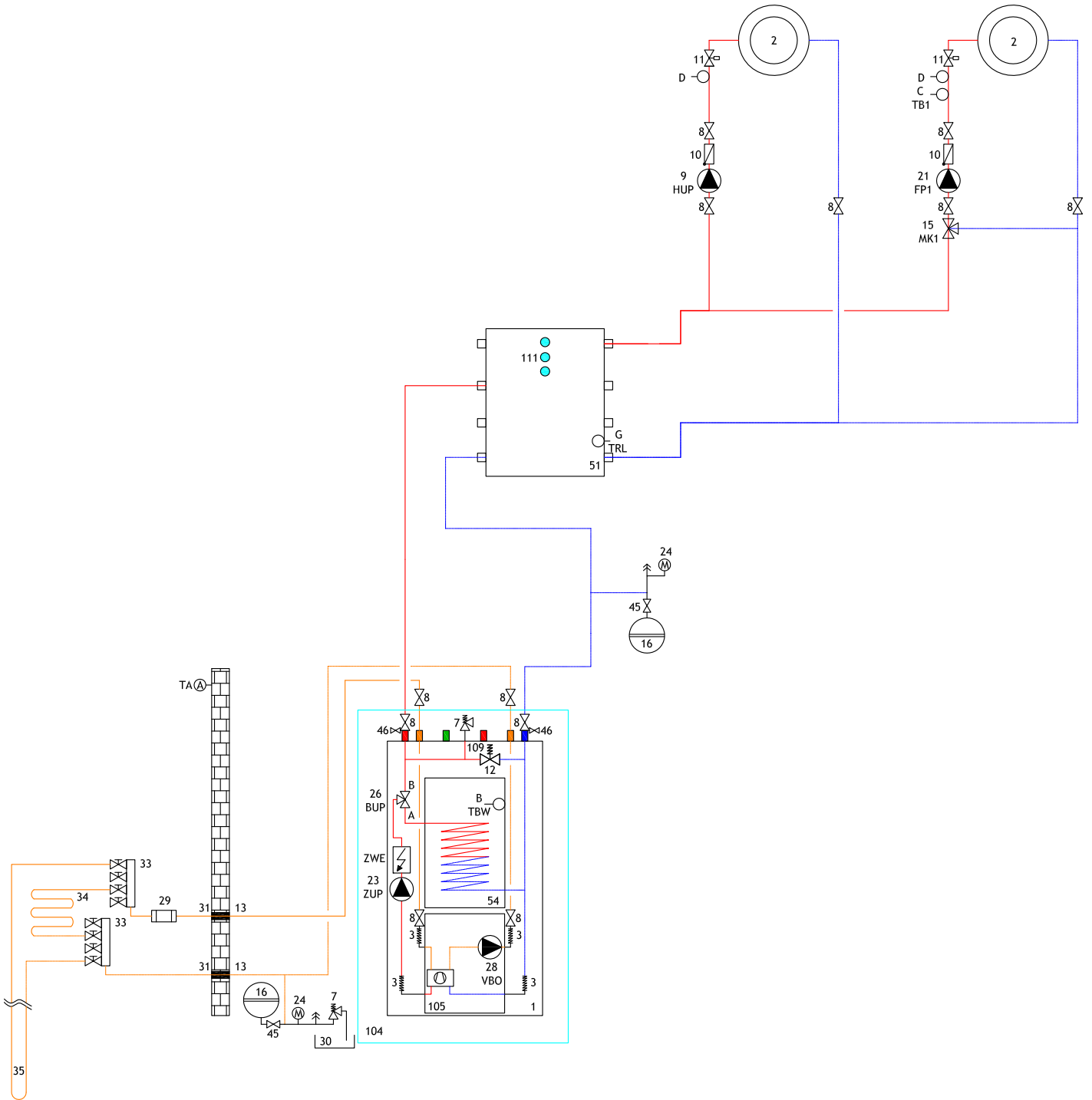



Hydraulic integration, unit variant K (cooling)

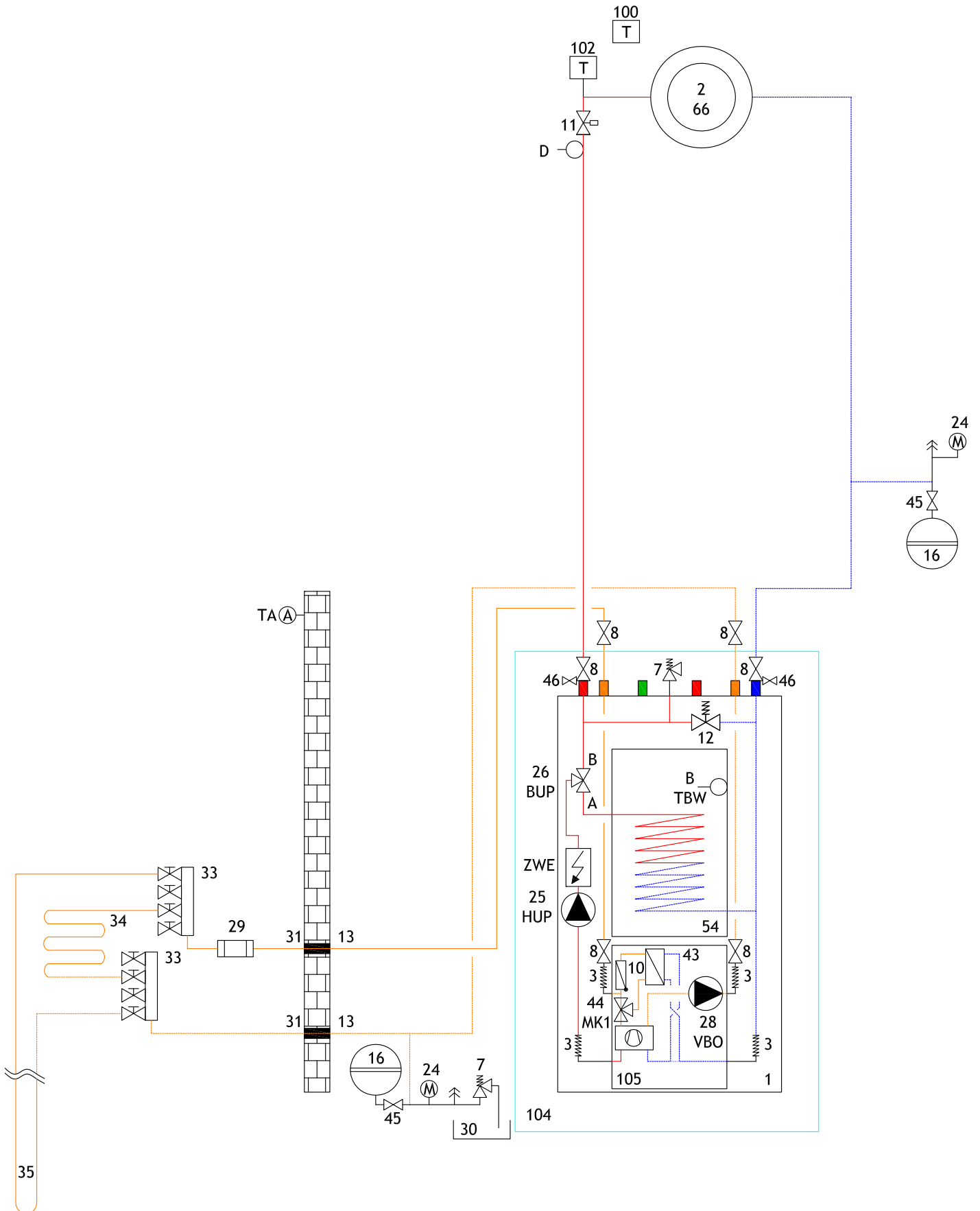

Legend hydraulic diagramm

1	Heat pump	51	Separation tank
2	Underfloor heating / radiators	52	Gas- or oil-boiler
3	Vibration isolation	53	Wood boiler
4	Sylomer strip machine underlay	54	Hot water cylinder
5	Closure and drainage	55	Brine pressure switch
6	Expansion vessel packing list	56	Swimming pool heat exchanger
7	Safety valve	57	Geothermal heat exchanger
8	Closure	58	Ventilation system
9	Heating circulation pump	59	Plate heat exchanger
10	Non return valve/ one way valve	61	Cooling cylinder
11	Individual room regulation	65	Compact distributor
12	Overflow valve	66	Fancoils
13	Steamtight insulation	67	Solar/ service water cylinder
14	Service water circulation pump	68	Solar/ service water cylinder
15	Mixer circuit three-way mixer (MK1 discharge)	69	Multifunction tank
16	Expansion vessel supplied by customer	71	Dual hydraulic module
18	Heating rod (heating)	72	Buffer tank wall mounted
19	Mixer circuit four-way mixer (MK1 charge)	73	Pipe lead-in
20	Heating rod (SW)	74	Ventower
21	Mixer circuit circulation pump (FP1)	75	Scope of delivery, hydraulic tower, dual
23	Feed circulating pump (reconnect the integrated circulating pump in the heat pump)	76	Fresh water station
24	Manifold	77	Scope of supply water/water booster
25	Heating circulation pump	78	Accessories water/water booster optional
26	Switching valve (heating/service water)(B = normally open)		
27	Heating element		
28	Brine circulation pump		
29	Dirt-trap 0.6 mm mesh		
30	Spill-tray für brine mix		
31	Wall breakthrough		
32	Inlet pipe		
33	Brine manifold		
34	Ground collector		
35	Ground sinkies		
36	Groundwater spring pump		
37	Wall bracket		
38	Flow switch		
39	Suction well		
40	Inverted well		
41	Rinse fitting heating circuit		
42	Circulation pump		
43	Brine / Water heat exchanger (cooling function)		
44	Three-way mixer valve (cooling function MK1)		
45	Cap valve		
46	Filler and drainage valve		
48	Domestic hot water charging pump		
49	Direction of groundwater flow		
50	Buffer storage		

TA/A	External sensor
TBW/B	Domestic hot water sensor
TB1/C	Feedwater sensor mixer circuits 1
D	Floor temperature limiter
TRL/G	Sensor external return
STA	Line pressure regulator valve
TRL/H	Sensor return (hydraulic module, dual)
79	Motor valve
80	Mixing valve
81	Split heat pump outdoor unit
82	Split heat pump indoor unit
83	Circulation pump
84	Switching valve
113	Connection 2nd heat generator
BT1	Outdoor temperature sensor
BT2	Flow temperature sensor
BT3	Return temperature sensor
BT6	Domestic hot water temperature sensor
BT12	Flow temperature liquefier
BT19	Temperature sensor immersion heater
BT24	Temperature sensor 2nd heat generator

Comfort board:

15	Mixer circuit three-way mixer (MK2-3 discharge)	100	Room thermostat for cooling (optional)
17	Temperature difference regulator	101	Controls supplied by customer
19	Mixer circuit four-way mixer (MK2 charge)	102	Dew-point monitor (optional)
21	Mixer circuit circulation pump (FP2-3)	103	Room thermostat for reference space in packing list
22	Swimming pool circulating pump	104	Supply heat pump
44	Three-way mixer valve (cooling function MK2)	105	Cooling circuit module box removeable for installation
47	Changeover valve swimming bath preparation(B = normally open)	106	Specific glycole mixture
60	Changeover valve cooling operation(B = normally open)	107	Scald protection / thermostatic mixer valve
62	Heat meter (optional)	108	Solar pump assembly
63	Changeover valve solar circuit(B = normally open)	109	Overflow valve must be closed
64	Cooling circulation pump	110	Packing list hydraulic tower
70	Solar separation module	111	Mounting for additional heating element
TB2-3/C	Feedwater sensor mixer circuits 2-3	112	Minimum distance to thermal decoupling of the mixing valve
TSS/E	Sensor, temperature difference control (low temperature)		
TSK/E	Sensor, temperature difference control (high temperature)		
TEE/F	Sensor external energy source		

Important notice!

These hydraulic diagrams are schematic representations and are for assistance only. They do not relieve of the obligation to carry out appropriate planning! They do not include all necessary shut-off valves, ventilator fittings or safety devices. These must be incorporated in accordance with the standards and regulations applicable to the respective installation. All country-specific standards, laws and regulations must be observed! The tubes have to be dimensioned according to the nominal volume flow of the heat pump resp. the free pressing of the integrated circulating pump. For detailed information and advice please contact our local sales partner!





Terminal diagram

WZSV 62(H)(K)3M

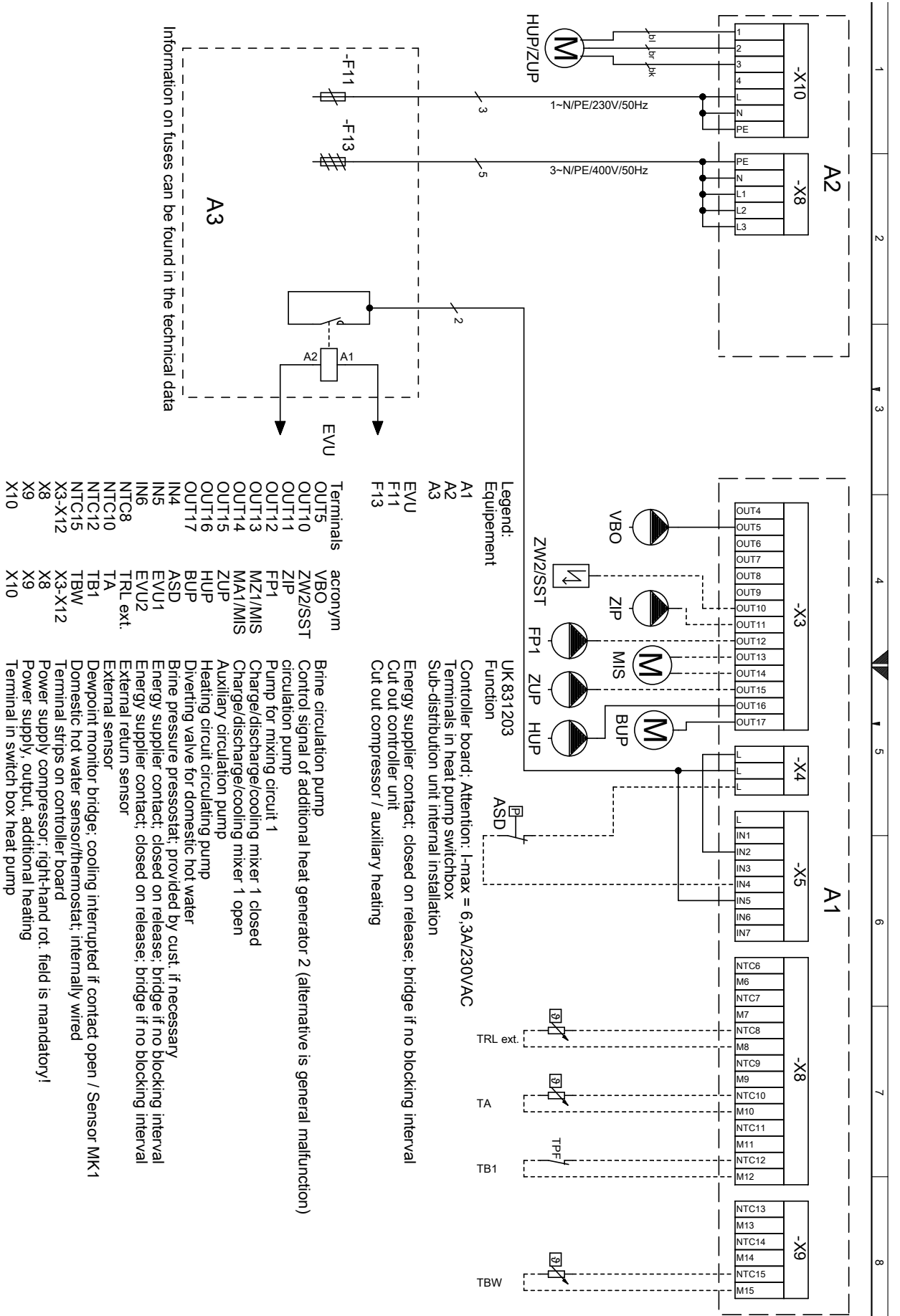



WZSV 162(H)(K)3M

Terminal diagram

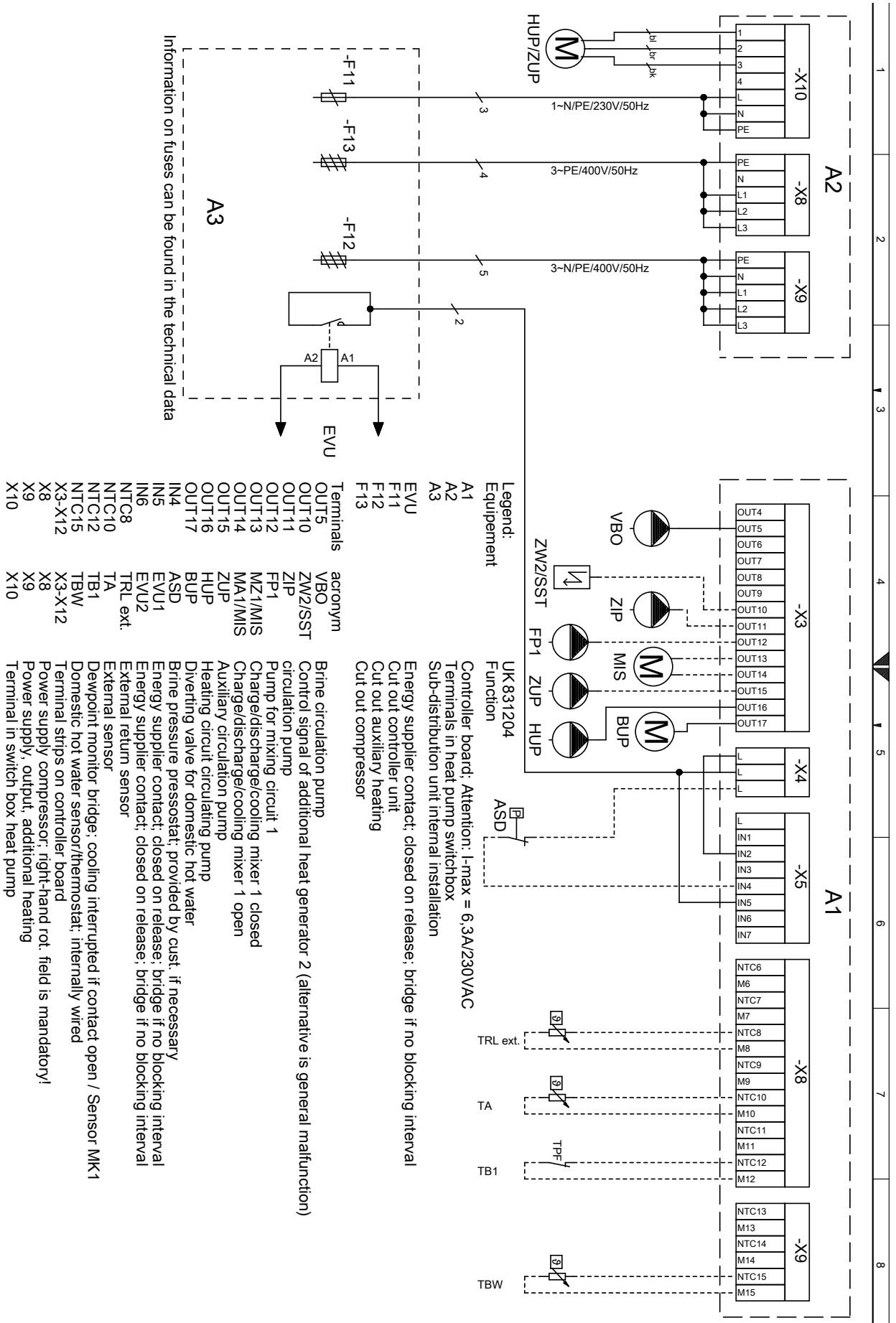

Legend:

Equipment	acronym
A1	VBO
A2	ZW2/SST
A3	ZIP
EVU	FP1
F11	MZ1/MIS
F12	MA1/MIS
F13	ZUP
Terminals	HUP
OUT5	BUP
OUT10	ASD
OUT11	EVU1
OUT12	EVU2
OUT13	IN6
OUT14	IN5
OUT15	IN4
OUT16	IN3
OUT17	IN2
	IN1
	NTC8
	NTC10
	NTC12
	NTC15
	TA
	TB1
	TBw
	X3-X12
	X8
	X9
	X10

Function

UK831204	Function
TR1	Brine circulation pump
TR2	Control signal of additional heat generator 2 (alternative is general malfunction)
TR3	circulation pump
TR4	Pump for mixing circuit 1
TR5	Charge/discharge/cooling mixer 1 closed
TR6	Charge/discharge/cooling mixer 1 open
TR7	Auxiliary circulation pump
TR8	Heating circuit circulating pump
TR9	Diverging valve for domestic hot water
TR10	Brine pressure pressostat; provided by cust. if necessary
TR11	Energy supplier contact; closed on release; bridge if no blocking interval
TR12	Energy supplier contact; closed on release; bridge if no blocking interval
TR13	External return sensor
TR14	Dewpoint monitor; bridge; cooling interrupted if contact open / Sensor MK-1
TR15	Domestic hot water sensor/thermostat; internally wired
TR16	Terminal strips on controller board
TR17	Power supply compressor; right-hand rot. field is mandatory!
TR18	Power supply; output; additional heating
TR19	Terminal in switch box heat pump



WZSV 62(H)(K)3M

Circuit diagram 1/3

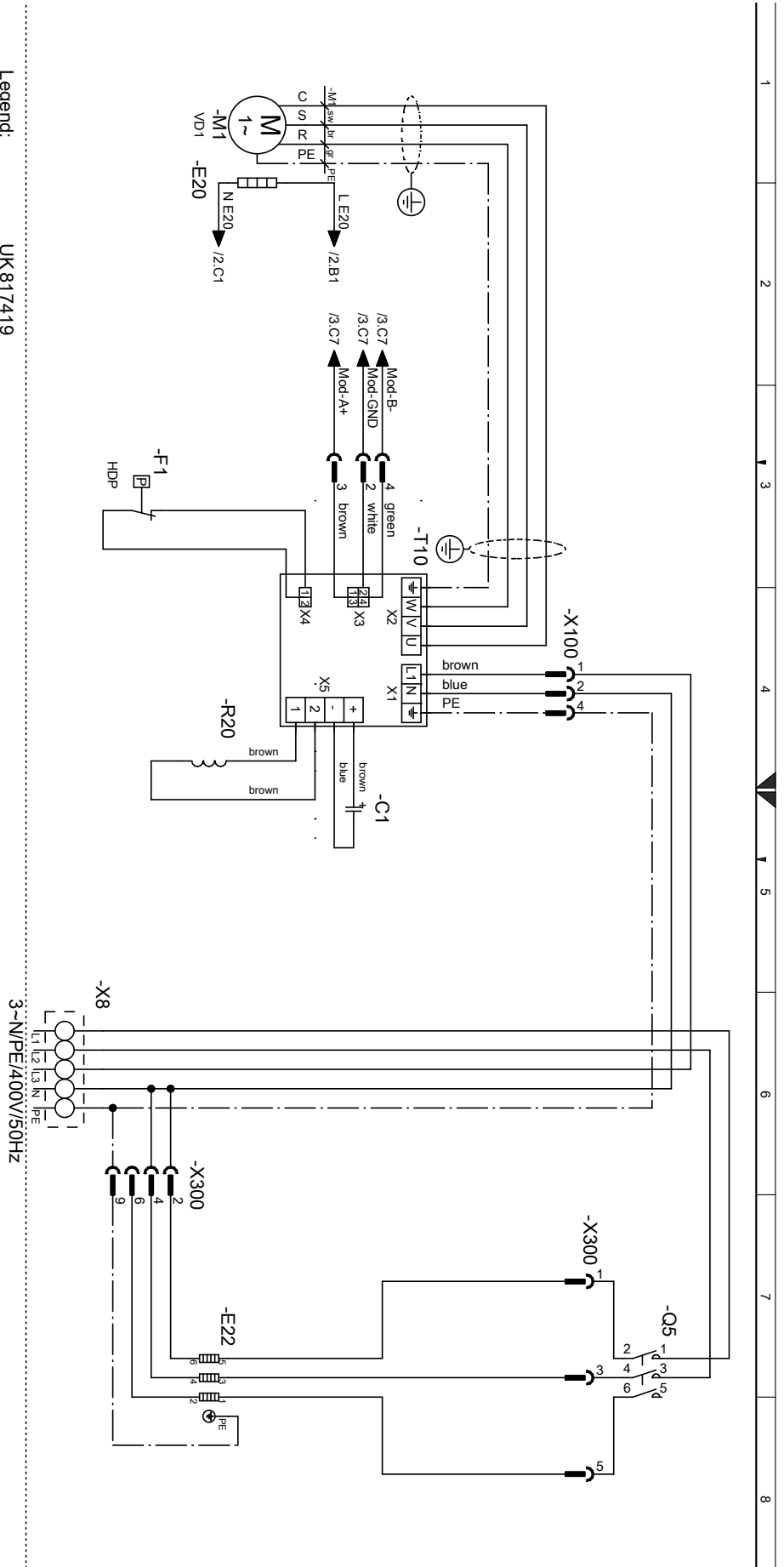

- Legend:
- | | |
|-----------|----------|
| Equipment | UK817419 |
| Function | |
- 3~N/PE/400V/50Hz L1,L2,L3,N,PE; power supply, output, compressor; clockwise rotary field is absolutely necessary!
- | | |
|------|--|
| C1 | capacitor |
| E20 | Sump heating for compressor 1 |
| E22 | Auxiliary heating |
| F1 | High-pressure switch |
| M1 | Compressor |
| O5 | Contactor for auxiliary heating |
| R20 | Line reactors |
| T10 | inverter |
| X100 | Distribution box power supply |
| X8 | Compressor output / control connector |
| X300 | Additional heating output connector, input |



Circuit diagram 2/3

WZSV 62(H)(K)3M

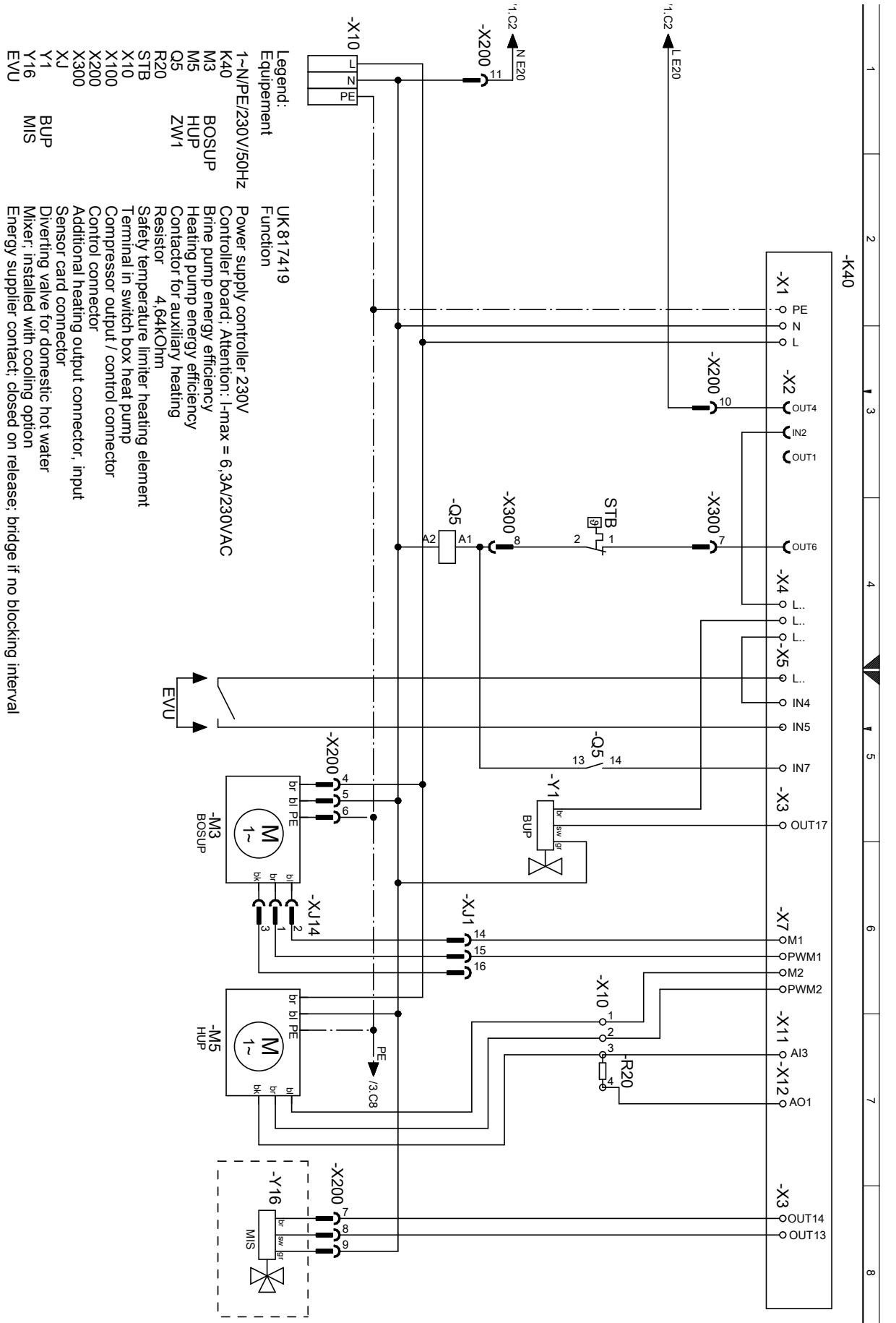



WZSV 62(H)(K)3M

Circuit diagram 3/3

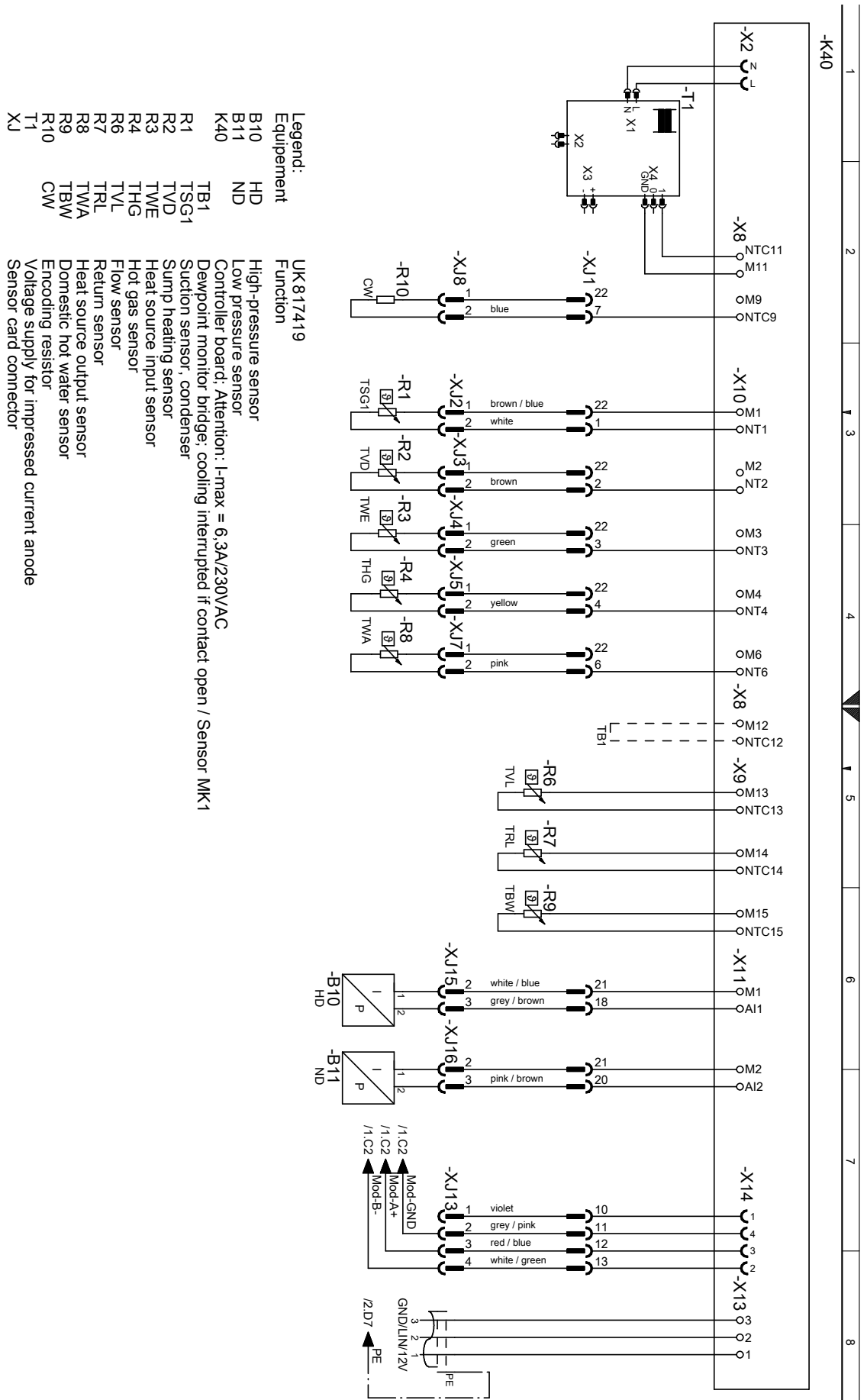



WZSV 162(H)(K)3M

Circuit diagram 1/3

- E20 Sump heating for compressor 1
- E22 Auxiliary heating
- M1 Compressor
- Q5 Contactor for auxiliary heating inverter
- Q10 main filter
- RF1 Distribution box power supply output compressor
- X8 Power supply additional heating: 3x400V
- X9 Compressor output / control connector
- X300 Additional heating output connector, input

Legend: UK 817420
Equipment Function

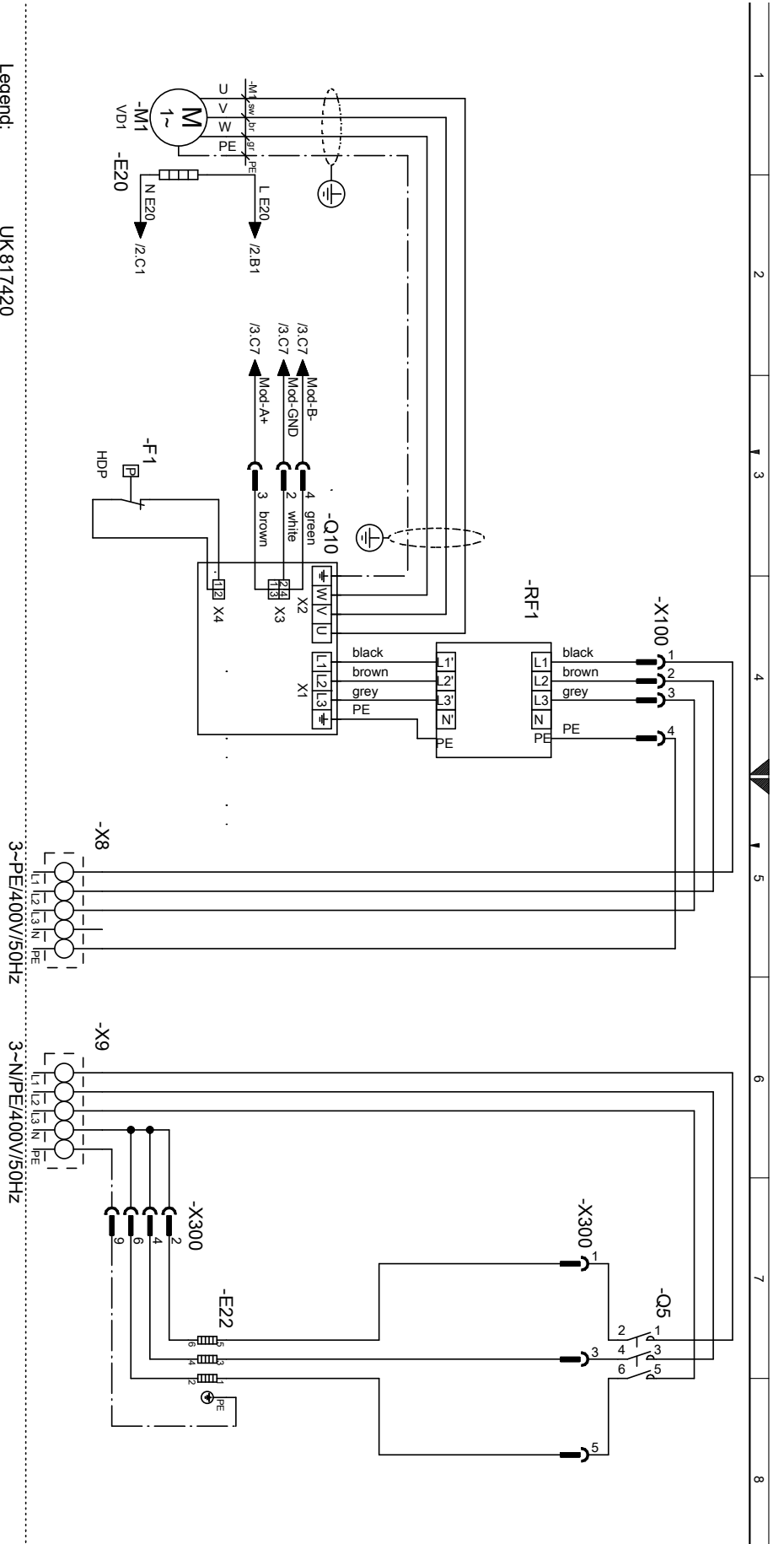



WZSV 162(H)(K)3M

Circuit diagram 2/3

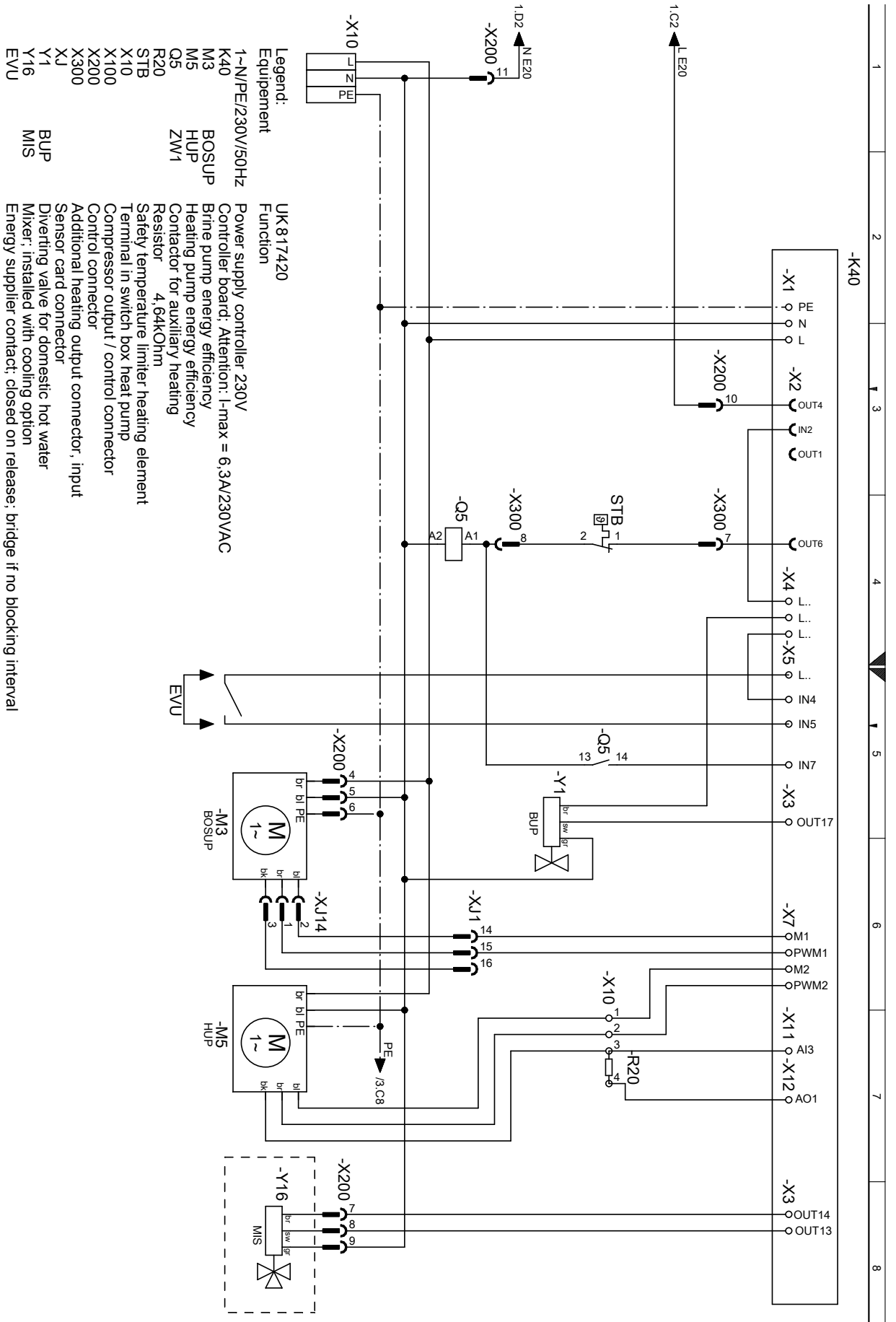



Circuit diagram 3/3

WZS 102(H)(K)3M – WZS 122(H)(K)3M

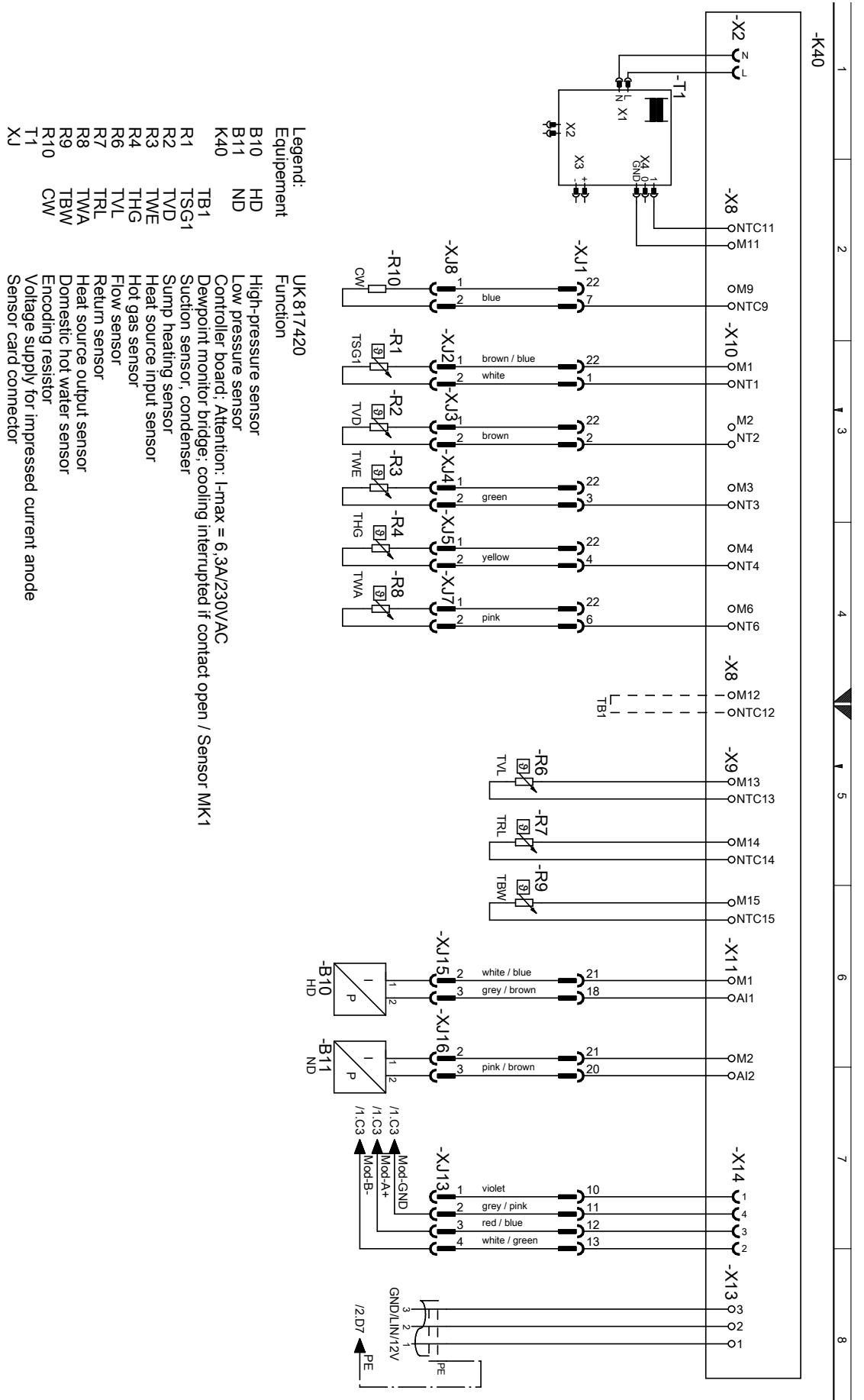



EC Declaration of Conformity in accordance with
the EC Machinery Directive 2006/42/EC, Annex IIA



The undersigned confirms that the following designated device(s) as designed and marketed by us fulfill the standardized EC directives, the EC safety standards and the product-specific EC standards. In the event of modification of the device(s) without our approval, this declaration shall become invalid.

Designation of the device(s)

Heat Pump



Unit model	Number	Unit model	Number
WZS 42H3M	10066041	WZS 42H3M	10067041
WZS 62H3M	10066141	WZS 62H3M	10067141
WZS 82H3M	10066241	WZS 82H3M	10067241
WZS 102H3M	10066342	WZS 102H3M	10067342
WZS 122H3M	10066442	WZS 122H3M	10067442
WZS 42K3M	10066541	WZS 42K3M	10067541
WZS 62K3M	10066641	WZS 62K3M	10067641
WZS 82K3M	10066741	WZS 82K3M	10067741
WZS 102K3M	10066842	WZS 102K3M	10067842
WZS 122K3M	10066942	WZS 122K3M	10067942
WZSV 62H3M	10072041	WZSV 62H3M	10072441
WZSV 162H3M	10072141	WZSV 162H3M	10072541
WZSV 62K3M	10072241	WZSV 62K3M	10072641
WZSV 162K3M	10072341	WZSV 162K3M	10072741

EC Directives

2006/42/EG

2006/95/EG

2004/108/EG

*97/23/EG

2011/65/EG

*** Pressure equipment component**

Category II

Module A1

Designated position:

TÜV-SÜD

Industrie Service GmbH (Nr.:0036)

Company:

ait-deutschland GmbH

Industrie Str. 3

93359 Kasendorf

Germany

Standardized EN

EN 378

EN 349

EN 60529

EN 60335-1/-2-40

EN ISO 12100-1/2

EN 55014-1/-2

EN ISO 13857

EN 61000-3-2/-3-3

Place, date:

Kasendorf, 20.03.2015

Signature:

Jesper Stannow

Head of Heating Development

UK

ait-deutschland GmbH
Industriestraße 3
D-95359 Kasendorf

E info@alpha-innotec.de
W www.alpha-innotec.de



alpha innotec – an ait-deutschland GmbH brand